



www.orthman.com

IMPLEMENT GUIDANCE SYSTEM
TRACKER IV

OPERATOR'S MANUAL

**ORTHMAN
MANUFACTURING
INCORPORATED**

STILL THE STRONGEST

**ORTHMAN MFG. INC.
75765 RD. 435
LEXINGTON, NE 68850**

OM07-12-01

Farm Safety

Contrary to the popular image of fresh air and peaceful surroundings, a farm is not a hazard-free work setting. Every year, thousands of farm workers are injured and hundreds more die in farming accidents. According to the National Safety Council, agriculture is the most hazardous industry in the nation.

How You Can Improve Farm Safety

You can start by increasing your awareness of farming hazards and making a conscious effort to prepare for emergency situations including fires, vehicle accidents, electrical shocks from equipment and wires, and chemical exposures. Be especially alert to hazards that may affect children and the elderly. Minimize hazards by carefully selecting the products you buy to ensure that you provide good tools and equipment. Always use seat belts when operating tractors, and establish and maintain good housekeeping practices. Here are some other steps you can take to reduce illnesses and injuries on the farm:

- Read and follow instructions in equipment operator's manuals and on product labels.
- Inspect equipment routinely for problems that may cause accidents.
- Discuss safety hazards and emergency procedures with your workers.
- Install approved rollover protective structures, protective enclosures, or protective frames on tractors.
- Make sure that guards on farm equipment are replaced after maintenance.
- Review and follow instructions in material safety data sheets (MSDSs) and on labels that come with chemical products and communicate information on these hazards to your workers.

Health and Safety Hazards on Farms

Farm workers including farm families and migrant workers are exposed to hazards such as the following:

Danger	Potential Effect or Injury	Prevention
Chemicals/Pesticides	Skin and respiratory injury or death	MSDS and proper Personal Protective Equipment. Review Manufacturers data sheets
Cold	Illness, Frostbite or death	Dress properly for the day.
Dust	Respiratory injury or explosive combinations	Be aware of your surroundings and activity
Electricity	Shock, burns, fire, death	Use a qualified professional for wiring dangerous electrical devices. Never overload a circuit. Replace damaged electrical devices or cords. Electrical tape will not insulate you from injury.
Grain bins, Silos	Entrapment, Suffocation, Explosion from formation of dangerous gases and poisoning.	Make sure the bin is properly ventilated and maintained. Never walk the grain.
Hand tools	Injury including cuts abrasions, electrocution, strains, sprains and death	Make sure you hand tools are in good condition. Never leave a damaged tooling accessible for someone else to use.
Highway traffic	Collisions resulting in injury or death	Follow regulations, stay alert. Avoid alcohol and use of communication devices while driving
Lifting and lifting devices	Back injury, sprains, strains. Falling material resulting in being struck or crushed by heavy material	Use proper lifting technique. Get help when the load is too heavy. Inspect chains, straps or cables routinely to make sure they are in good condition.
Livestock handling	Serious injury or death resulting from being pinned struck or trampled.	Always make sure you have adequate room and an escape route
Machinery/Equipment	Cuts, abrasions, amputations, death.	Thoroughly read and understand your Owners Equipment Manual. Never operate the equipment without guards in place. Make sure the equipment can not be energized or otherwise put into operation while you are working on it.
Manure pits	Explosion from formation of dangerous gases. Suffocation. Poisoning	Proper maintenance.
Mud	Sprains, strains, entrapment and suffocation. Eye injury and skin irritation.	Proper Personal Protective Equipment. In some conditions a "Spotter" may be needed.
Noise	Hearing damage	Personal Protective Equipment.
Ponds	Drowning	Wear a life preserver and make sure help is readily available.
Slips/Trips/Falls	Sprains, strains, back and neck injury, bone breaks or death	Keep work area free from clutter and organized. If working on anything elevated make sure you have appropriate guarding and/or fall protection such as a harness and lanyard.
Sun/Heat	Sun burn, Heat Stroke, shock, death	Use common sense on excessively hot days, use sun screen, wear a hat and stay hydrated.
Toxic gases	Skin and respiratory injury or death. Explosion.	MSDS and proper Personal Protective Equipment. Review Manufacturers data sheets
Tractors	Cuts, abrasions, amputations, death.	Thoroughly read and understand your Owners Equipment Manual. Never operate the equipment without guards in place. Anti-roll over devices.
Wells	Electrocution, amputation, death	Avoid contact with water while working on an electrical device. Always be sure the equipment can/will not be energized during repair or maintenance. Make sure all guarding is in place.
Severe Weather	Electrocution, "struck by" injuries, death	Move to a safe place. Lightning, hail and tornadoes are unpredictable.

Orthman Manufacturing, Inc. does not limit the potential effects or injuries nor prevention measures to those listed above. They are provided solely as a guideline to making your farm life safer. Always consult your Owner/Operators Manual for specific tool and equipment safety requirements.

High Risk Factors on Farms

The following factors may increase risk of injury or illness for farm workers:

- **Age** – Injury rates are highest among children age 15 and under and adults over 65.
- **Equipment and Machinery** – Most farm accidents and fatalities involve machinery. Proper machine guarding and doing equipment maintenance according to manufacturers' recommendations can help prevent accidents.
- **Protective Equipment** – Using protective equipment, such as seat belts on tractors, and personal protective equipment (such as safety gloves, coveralls, boots, hats, aprons, goggles, face shields) could significantly reduce farming injuries.
- Take precautions to prevent entrapment and suffocation caused by unstable surfaces of grain storage bins, silos, or hoppers. Never "walk the grain."
- Be aware that methane gas, carbon dioxide, ammonia, and hydrogen sulfide can form in unventilated grain silos and manure pits and can suffocate or poison workers or explode.
- Take advantage of safety equipment, such as bypass starter covers, power take-off master shields, and slow-moving vehicle emblems.
- **Medical Care** – Hospitals and emergency medical care are typically not readily accessible in rural areas near farms.

The Benefits of Improved Safety and Health Practices

Orthman Manufacturing Provides this document in the hope that everyone that has a job to do, does it SAFELY. Our goal and yours should be to end each day in the best possible health. Better safety and health practices reduce fatalities, injuries, and illnesses as well as associated costs such as workers' compensation insurance premiums, lost production, and medical expenses. A safer and more healthful workplace improves morale and productivity.



INTRODUCTION

The Orthman Tracker IV Implement Guidance system was developed to provide industry leading precision implement guidance. The Tracker IV is a supplemental, rearward mounted, implement able to be utilized with virtually any existing row crop implement on the market. Combining the unprecedented precision of the Tracker IV with the well known Orthman durability results in the most advanced implement guidance system in agriculture.

Tracker IV mounting arms mount directly to an existing toolbar and extend rearward to provide clearance for existing row units. The bolt-on mounting arms are constructed of 5" x 7" x 3/8" wall tubing.



(6-Blade Tracker IV Guidance System mounted to a 1900 Series Planter Toolbar)

The Tracker IV frame consists of a 5" x 7" x 3/8" wall cross tube positioned similar to that of the existing toolbar. A spindle, yoke, and steering blade are then assembled allowing the steering blade to protrude into the ground surface. The Tracker IV is available in 2, 3, 4, and 6 (pictured above) blade models. Implement size and quantity of steering blades are in direct proportion, with consideration also given to the objective of the implement. Cross tube lengths vary dependent upon the desired quantity of steering blades.

The positioning or angle of the steering discs allows the Tracker IV to effectively steer implement. Drawn implements have the ability to travel laterally more so than integral implements attached close coupled to the towing device. NOTE: Sway bars should be removed from any tractor towing a 3 point hitched implement to allow the Tracker to adequately correct implement position.



INTRODUCTION

The probe box is mounted to the existing toolbar. The probe box is outfitted with devices (feeling rods, probe balls) to determine the position of the implement in regards to the desired position. This information is continuously sent from the probe box to the console which is positioned in the tractor cab. The console remote probe button allows the operator to raise and lower the probing device at any time.

The Tracker IV feedback sensor is simultaneously receiving information in regards to the position of the steering blades. This information is also being continuously sent to the console.



(2-Blade Tracker IV Guidance System mounted to a 6 row 30" Orthman 1tRIPr)

The console is always receiving information from both the probe box (implement position) and the feedback sensor (steering blade position). The console processes information and then sends that information to the proportional valve.

The proportional valve controls the hydraulic cylinder to stroke to a certain position. The hydraulic cylinder essentially provides the steering discs with the force needed to pivot while submerged in soil, returning the implement to the desired position. Once the probe box senses that the implement is in the correct position, the steering blades will return to center and the implement will proceed until future probe box information prompts pivoting of steering blades.

Steering blades are connected by tie rods. A single hydraulic cylinder allows all blades to simultaneously pivot to the same degree providing consistent implement tracking correction.



INTRODUCTION

The Tracker IV consists of an endless and uninterrupted flow of information into the console from the probe box (implement current position) and the feedback sensor (steering blade position). The console continuously is processing this information in order to send information to the proportional valve. The proportional valve then instructs the hydraulic cylinder to extend or retract to cause the steering blades to pivot and steer the implement back to the intended course.

The Tracker IV is designed to improve the field accuracy of the implement operator. The Tracker IV is able to be utilized on an array of implements to increase operator ease on multiple platforms.



(2-Blade Tracker IV Guidance System mounted to a 6 row 30" Orthman 1tRIPr)

This manual is sequentially designed and written and is considered to be an integral component of the Tracker IV and is designed to educate the owner and operators regarding safety, preparation and set-up, installation, field settings, component identification, maintenance, and troubleshooting of the Tracker IV. The owner and all operators are responsible for reading and understanding the entire content of this manual before attempting to manipulate the Tracker IV in any way. If all suggestions and instructions in the manual are followed, all adjustments, operations, and maintenance will be simplified and easier for the personnel involved in the operation of the Tracker IV. This manual is designed to keep the operator safe and knowledgeable as well as prolong the life of the implement, minimize downtime, and maximize profits. This manual should accompany the implement if it were ever to be sold.

We would like to thank you for placing your confidence in Orthman Mfg., Inc.
Your Tracker IV is manufactured to meet the highest standards and is built with precision

THANK YOU FOR CHOOSING ORTHMAN.

STILL THE STRONGEST.



INTRODUCTION

WARRANTY

Orthman Mfg., Inc. warrants the whole goods products it manufactures to be free from defects in material or workmanship for a period of one (1) year from the date of sale of the product(s) to the original user. Products not manufactured, but supplied by Orthman Mfg., Inc. on Orthman products, are subject to, conform with, and are limited to the warranty of our suppliers.

Orthman Mfg., Inc. warrants the parts it manufactures to be free from defects in material or workmanship for a period of ninety (90) days from the date of delivery of the product(s) to the original user. Products not manufactured, but supplied by Orthman Mfg., Inc. on Orthman products, are subject to, conform with, and are limited to the warranty of our suppliers.

Warranty of Orthman whole goods and/or parts applies only to material and workmanship. Misuse, misapplication, neglect, alteration, accident, normal wear, or acts of God affecting Orthman products are not eligible for warranty.

Warranty of serial numbered goods will only be considered if the product has a completed Warranty Registration on file at Orthman. This Warranty Registration must be completed and returned to Orthman within thirty (30) days of the sale of the product(s) to the original user. *No serial numbered goods or related parts and/or labor will be warranted without a Warranty Registration on file.* Warranty issues falling within the first thirty days of a product's use will be handled at the discretion of Orthman. Warranty of parts will not require a Warranty Registration, but proof of date of delivery of the product to the original customer must be provided.

WARRANTY CLAIMS: A warranty claim and request to return defective product(s) must be presented to the Orthman Service Department by the selling dealer describing the defect in material or workmanship of an Orthman product(s) within ten (10) days of its discovery. This claim may be made via phone, e-mail, fax, or written request. Claims for warranty of serial numbered goods must include the Orthman product serial number and model number. Claims for warranty of parts will not require a product serial number or model number, but must be identified by an Orthman part number. Claims for warranty of whole goods or parts must also include proof of date of sale of the product to the original customer by an Orthman dealer.

The Orthman Service Department will proceed in making a preliminary decision as to the eligibility of the claim for warranty consideration. After the Orthman Service Department deems it necessary to proceed with warranty consideration, a Return Goods Authorization (RGA) will be completed by the Orthman Service Department in conjunction with the selling dealer. Upon completion of the RGA, the defective product(s) must be returned to Orthman to ensure warranty consideration. Defective product(s) must be returned to Orthman by either the selling dealer or the customer. Customer delivery of defective product(s) must be approved by Orthman and the selling dealer prior to delivery. The defective product(s) in question must be sent, freight prepaid, within sixty (60) days of the discovery of the product(s) failure and initial warranty claim. Replacement product(s) may be sent to the selling dealer, directly to the customer, or picked up at the Orthman facility. Replacement product(s), sent directly to the customer or picked up must be approved by Orthman and the selling dealer. At the discretion of the Orthman Service Department, replacement product(s) may be sent prior to, or after, the Orthman Service Department receives the defective product(s).

Any variation in the above procedure is at the sole discretion of the Orthman Service Department.

No products will be accepted at Orthman without all proper paperwork completed including Warranty Registration and RGA(s).

Parts returned to Orthman without proper authorization will be returned to the sender at the sender's expense.

Orthman agrees to handle all warranty claims in a timely manner and will inform dealers of any revisions or modifications to the Orthman Warranty Policy. Eligible warranty claims will be processed by Orthman within sixty (60) days of receiving failed product(s) or a valid service or repair labor claim. Eligible warranty claims regarding returned product(s) or service and/or repair labor will be paid through a credit memo issued to the appropriate dealer's account as determined by the Orthman Service Department.

If a warranty claim is found to be ineligible for warranty coverage, the Orthman Service Department will be responsible to inform the dealer in order to determine the course of action to be taken. Orthman reserves the right to make changes in specification and design without notice and without incurring any obligations to owners of products previously sold.

© Copyright 2006
Orthman Manufacturing Inc.
Lexington, Nebraska
All rights reserved.

Orthman provides this manual without warranty of any kind, expressed or implied. This manual reflects the product at the time of publication. All information within is based upon current information on the publication date. Orthman assumes no responsibility for damages incurred due to the use of the illustrations, information, and specifications within this publication.



TABLE OF CONTENTS

INTRODUCTION

General Information - Tracker IV.....	1 - 1
Warranty Information.....	1 - 4
Table of Contents.....	1 - 5

IMPORTANT SAFETY INFORMATION

Safety Information.....	2 - 1
Safety Decals..... <input type="checkbox"/>	

MAJOR COMPONENT IDENTIFICATION

Component Identification.....	3 - 1
Hardware Identification (tillage).....	3 - 2
Hardware Identification (planter).....	3 - 3
Electrical Component Identification.....	3 - 4
Electrical Component Routing.....	3 - 5

PREPARATION AND SETUP

Mounting Arm Clamp to Toolbar Installation.....	4 - 1
Mounting Arm Clamp to Toolbar and 5 x 7 Orthman Hitch Installation.....	4 - 3
Arm to Clamp Installation.....	4 - 5
Turnbuckle Installation.....	4 - 6
Blade and Hub Assembly Installation.....	4 - 8
Yoke to Frame Installation.....	4 - 9
Blade and Hub to Yoke Installation.....	4 - 10
Frame to Arm Installation (tillage scenario).....	4 - 11
Frame to Arm Installation (planting scenario).....	4 - 12
Probe Box Installation.....	4 - 13
Feeler Rod Installation.....	4 - 16
Double Probe Ball Installation.....	4 - 17
Triple Probe Ball Installation.....	4 - 18
Hydraulic Component Identification.....	4 - 19
Electrical Component Routing.....	4 - 20
Probe Lift Switch Installation.....	4 - 21

FIELD SETTINGS

Blade Depth Adjustment.....	5 - 1
Probing Device Depth Adjustment.....	5 - 4
Powering Up the Console.....	5 - 6
Left and Right Offset.....	5 - 7



INTRODUCTION

TABLE OF CONTENTS

PERFORMANCE SETTINGS

Basic Performance Settings.....	6 - 1
Utility Functions.....	6 - 5

TROUBLESHOOTING

System Status Error Codes.....	7 - 1
Field Service Diagnostic Modes.....	7 - 5

PARTS IDENTIFICATION

Tracker Arm Clamp for 7 x 7 Toolbar.....	8 - 1
Tracker Arm Clamp for 7 x 7 Toolbar and Orthman 5 x 7 Hitch.....	8 - 2
Standard Turnbuckle.....	8 - 3
Cushion Turnbuckle.....	8 - 4
Arm Assemblies.....	8 - 5
Arm Assembly for 1800 Toolbar.....	8 - 6
Arm Assembly for 1900 Toolbar.....	8 - 7
Blade, Hub, and Yoke Assembly.....	8 - 8
Sensor Spindle Assembly.....	8 - 9
Standard Spindle Assembly.....	8 - 10
Probe Box Assembly.....	8 - 11
Feeler Rod Package Assembly.....	8 - 12
Double In-Line Probe Ball Assembly.....	8 - 13
Triple Probe Ball Package Assembly.....	8 - 14
Tie Rod Assemblies.....	8 - 15
Electrical Cables and Components.....	8 - 16
Manifold Assembly.....	8 - 17



SAFETY INFORMATION

SAFETY ALERT SYMBOL



The **SAFETY ALERT SYMBOL** warns of potential hazards to personal safety and that extra precautions must be taken. When you see this symbol, carefully read the message(s) that follow. Follow all recommended precautions and safe operating practices in this manual.

Hazard control and accident prevention are dependent upon the safety awareness and proper training of personnel involved in the operation of this implement.

BE AWARE OF SIGNAL WORDS

SIGNAL WORDS designate a degree or level of **HAZARD** seriousness. These signal words include:



RED

DANGER indicates a hazardous situation that, if not avoided, will result in death or serious injury. Danger is limited to extreme situations, typically for machine components which for functional purposes, cannot be guarded.



ORANGE

WARNING indicates a potentially hazardous situation that, if not avoided, could result in death or serious injury. Warning includes hazards that are exposed when safety guards are removed. Warning may also be used to alert against unsafe practices.



YELLOW

CAUTION indicates a potentially hazardous situation that, if not avoided, may result in minor or moderate injury. Caution may also be used to alert against unsafe practices.

SHUTDOWN AND STORAGE



AVOID CRUSHING. Make sure all personnel are clear of the implement. Lower implement to the ground, place tractor in park, turn off engine, and remove key.



USE BAR STANDS AND CYLINDER STOPS TO SUPPORT THE IMPLEMENT.

Store implement on a clean, dry, and level surface. An uneven surface could cause implement to shift or fall, resulting in injury or death, as well as implement damage. Securely support all implement components that must be raised. Store implement away from human activity.



SAFETY INFORMATION

CAUTION

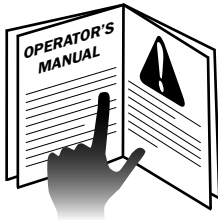

⚠ FOR YOUR PROTECTION

READ AND UNDERSTAND THE ENTIRE CONTENT OF THIS MANUAL BEFORE OPERATING OR SERVICING IMPLEMENT. Read and understand all operator manuals for the machinery used in conjunction with the Tracker IV.

Carefully **READ ALL SAFETY DECALS** in this manual as well as on the implement. Keep implement clean so decals are easily visible. Keep all safety decals in good, clean, and legible condition. Immediately replace damaged and/or missing decals. Replacement decals are available from your Orthman dealer.

Learn to operate the implement and all components properly. Do not let others operate implement without proper instruction. Unauthorized implement modifications may impair function and safety. If you do not understand any content in this manual or need assistance, contact your Orthman dealer.

(Orthman Manufacturing Inc. - 75765 Rd.435 - Lexington, NE 68850 - (308) 324-4654)

⚠ EQUIPMENT SAFETY GUIDELINES

Operator safety is the primary concern when designing an Orthman implement. Orthman integrates as many safety features into the implement as possible. You can avoid many hazards and possible accidents by observing precautions in this safety section.

Insist that yourself and personnel working with and around you follow all safety precautions. Be cautious when working with or around implement to avoid injury.



SAFETY INFORMATION

SAFE TRANSPORT

Engage transport locking devices and cylinder stops prior to transport.

Plan your route to avoid traffic. Yield to traffic in all situations.

Maximum transport speed is 20 mph (32 kph). Various conditions will require reduced speed. Travel at speeds that allow for adequate control of stopping and steering.



AVOID ELECTROCUTION. Be aware of overhead power lines. Contact or close proximity to power lines can result in injury or death. Use extreme care when operating implement near power lines.

Know implement transport height and gross weight. Avoid overhead obstructions not allowing your transport height. Do not use bridges rated below implement gross weight.



Make sure a slow moving vehicle (SMV) placard is mounted to the implement and is easily visible to other motorists.

Make allowances for implement size when transporting. Sudden braking can cause a towed load to swerve and/or rollover. Never use independent braking with implement in tow as loss of control and/or rollover can result. Reduce speed if towed implement is not equipped with brakes.



Do not coast. Always keep tractor or towing device in gear to provide engine braking when traveling downhill.

Comply with state and local laws governing implement transport.

WARNING AND SAFETY LIGHTS



Oversized implements and slow moving vehicles create a hazard when transported on public roads.

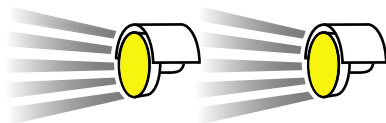

Make sure all warning, safety lights, and turning signals are working and clean. Use safety lighting when using public roads day and night. Replace missing or damaged lights immediately. Comply with state and local laws governing implement safety lighting.



SAFETY INFORMATION

SAFE OPERATION

CAUTION

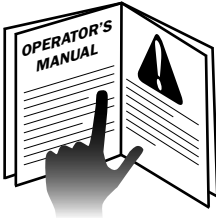

READ AND UNDERSTAND THE ENTIRE CONTENT OF THIS MANUAL BEFORE OPERATING OR SERVICING IMPLEMENT. Implement is to be operated by qualified personnel only. Never let children operate implement. A complete understanding of safety precautions, operation, and maintenance is mandatory before implement use.



AVOID ELECTROCUTION. Be aware of overhead power lines. Contact or close proximity to power lines can result in injury or death. Use extreme care when operating implement near power lines.

Know implement transport height and gross weight. Avoid overhead obstructions not allowing your transport height. Do not use bridges rated below your gross weight.



AVOID ROLLOVER. Do not fold or unfold implement and avoid sharp turns when on a hillside, as shift of weight could cause rollover. Operate implement at a safe distance from terrain irregularities and other obstructions that could cause rollover.



AVOID CRUSHING. Make sure all personnel are clear of implement at all times implement is in motion. Be aware of obstructions above, below, and around implement when in operation or transport. Injury or death can result from being struck by the implement.

NO RIDERS



NEVER ALLOW RIDERS ON TRACTOR OR IMPLEMENT. Riders hinder operator visibility and can be thrown from the implement and/or be struck by foreign objects resulting in injury or death.



SAFETY INFORMATION

PRACTICE SAFE MAINTENANCE

Proper maintenance is your responsibility. Maintenance neglect and/or poor maintenance practices can result in injury or death. Always use the proper tools to maintain implement.

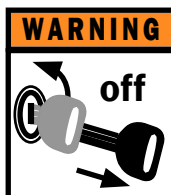

AVOID CRUSHING. Make sure all personnel are clear of the implement. Lower implement to the ground, place tractor in park, turn off engine, and remove key.



USE BAR STANDS TO SUPPORT THE IMPLEMENT. Store implement on a clean, dry, and level surface. An uneven surface could cause implement to shift or fall, resulting in injury or death, as well as implement damage. Securely support all implement components that must be raised. Store implement away from human activity.



AVOID ENTANGLEMENT. Never lubricate or service implement in motion. Keep away from power driven parts when in motion. Disengage power sources prior to maintaining implement. Injury or death can result from contact with power driven parts when in motion.



AVOID CRUSHING. Do not stand between the tractor and implement when connecting or disconnecting implement. Injury or death can result from being trapped between the tractor and implement.



Escaping pressurized hydraulic fluid can penetrate skin, resulting in injury or death. Relieve hydraulic system pressure before connecting or disconnecting tractor. Use cardboard or wood, **NOT BODY PARTS**, to check for suspected hydraulic leaks. Wear protective gloves and safety glasses or goggles when working with hydraulic systems. If an accident occurs, see a doctor immediately for proper treatment.



SAFETY INFORMATION

PRACTICE SAFE MAINTENANCE



Never operate a combustion engine in an enclosed area. Make sure there is adequate ventilation. Exhaust fumes can cause asphyxiation.



Service tires safely. Tire and rim separation can result in serious injury or death. Do not over inflate LAW tires. Tires should never exceed 35 psi. Only mount or dismount tires if you possess the proper equipment, otherwise contact a trained professional. Always maintain correct tire pressure. Inspect tires and wheels daily. Do not operate tires with inadequate pressure, cuts, visible damage, or missing hardware.



Be extremely careful working around unshielded sharp edges. Injury may result from contact with sharp edges.

Keep all parts in good condition and properly installed. Replace damaged or missing parts immediately.

Remove tools and unused parts prior to implement operation.

PREPARE FOR EMERGENCIES



Be prepared for a fire. Keep a readily accessible fire extinguisher at all times.

Keep a readily accessible stocked first aid kit and emergency phone numbers for your doctor, hospital, ambulance, and fire department.

Wear protective clothing and equipment. Wear clothing appropriate for the situation. Protect your eyes, ears, hands, and feet with the use of protective goggles, ear plugs, gloves, boots, etc.



SAFETY INFORMATION

ANHYDROUS AMMONIA - LIQUID FERTILIZER

Lift assist wheels can be accessorized with cross tube packages often utilized to pull nurse tanks in order to incorporate fertilization within the particular application.



ANHYDROUS AMMONIA (NH₃) AND LIQUID FERTILIZER APPEARS HARMLESS. DIRECT EXPOSURE TO NH₃ OR LIQUID FERTILIZER IS EXTREMELY DANGEROUS AND CAN RESULT IN INJURY AND/OR DEATH.

Keep a clean supply of water readily accessible in case of exposure to NH₃ or liquid fertilizer.

Wear protective goggles and gloves when working with NH₃ or liquid fertilizer. Be sure all persons involved in the operation are properly trained concerning the dangers and precautions involved in the application of NH₃ or liquid fertilizer.

If you choose to apply NH₃ or liquid fertilizer, it is advisable to consult documented information regarding safe handling and application of NH₃ or liquid fertilizer.

Information is available from the following recognized sources:

1. American National Standards Institute - ANSI - www.ansi.org - (212) 642-4900
2. Material Safety Data Sheets - MSDS - www.msdsonline.com
3. National Safety Council - www.nsc.org/necas
4. The Fertilizer Institute - www.tfi.org
5. United States Department of Transportation - D.O.T. - www.dot.gov
6. Compressed Gas Association - www.cganet.com

SAFETY NEVER HURTS

CAUTION

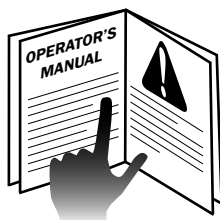

READ AND UNDERSTAND THE ENTIRE CONTENT OF THIS MANUAL BEFORE OPERATING OR SERVICING IMPLEMENT.

Understand all implement functions.

Never stand between tractor and implement when connecting or disconnecting implement.

Be aware of all surroundings before moving implement.

Operate implement from operator's seat only.

Never mount or dismount a moving tractor.

Never leave engine running when implement is unattended.

Keep away from power driven parts when in motion.

Make sure all personnel are clear before lowering implement to the ground.



SAFETY INFORMATION

SAFETY DECALS - OMI DECALS

DANGER

WARNING

CAUTION

Safety decals promote awareness and knowledge concerning safe operation and maintenance of the implement.

Carefully **READ ALL SAFETY DECALS** in this manual as well as on the implement. Keep implement clean so decals are easily visible. Keep all decals in good and legible condition. Immediately replace damaged and/or missing decals. Replacement decals are available from your Orthman dealer.

To install decals: Thoroughly clean area where decal is to be placed and attach decal void of bubbles. Refer to this safety information section for proper decal placement.

Decal illustrations below pertain to all Tracker IV's regardless of blade quantity.

153-173

RED RETROREFLECTIVE
(2) per Tracker steering frame

153-171

ORANGE FLORESCENT
(2) per Tracker steering frame

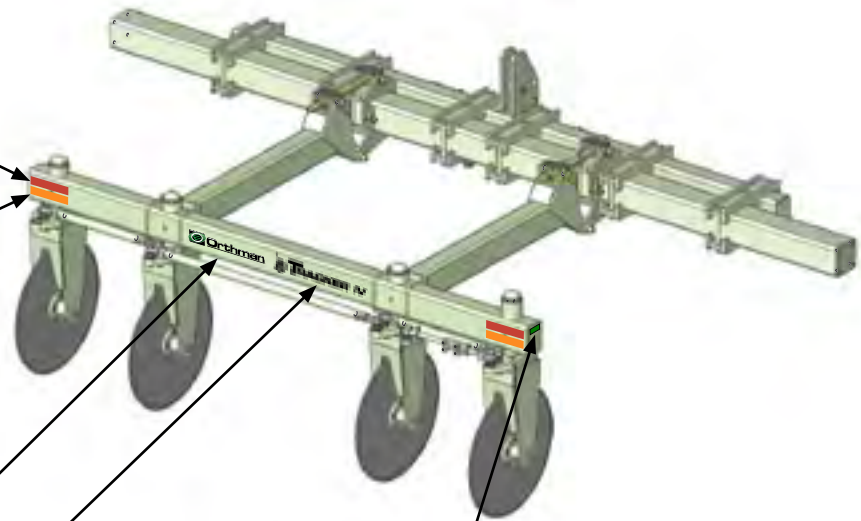

153-011



SAFETY INFORMATION

SAFETY DECALS - OMI DECALS

CAUTION

1. Read and understand all operator manuals before implement use.
2. Follow all tractor or towing device operating procedures and safety guidelines.
3. Do not allow riders on implement.
4. Lower implement to the ground, place tractor in park, turn off engine, and remove key. Wait for all moving parts to come to a complete stop before working on implement.
5. Be extremely careful working around unshielded sharp edges.
6. Make sure all safety lighting and decals are clean. Use hazard lights when in transport.
7. Engage all safety devices before transporting or working beneath implement.
8. Contact or close proximity to power lines can result in electrocution.
9. Review all safety instructions with all operators on a frequent basis.

153-044

DANGER

HIGH-PRESSURE FLUID HAZARD

To prevent serious injury or death:

- Relieve pressure on hydraulic system before servicing or disconnecting hoses.
- Wear proper hand and eye protection when searching for leaks. Use wood or cardboard instead of hands.
- Keep all components in good repair.

153-528

(1) per Tracker steering frame
(1) per right hand mounting arm

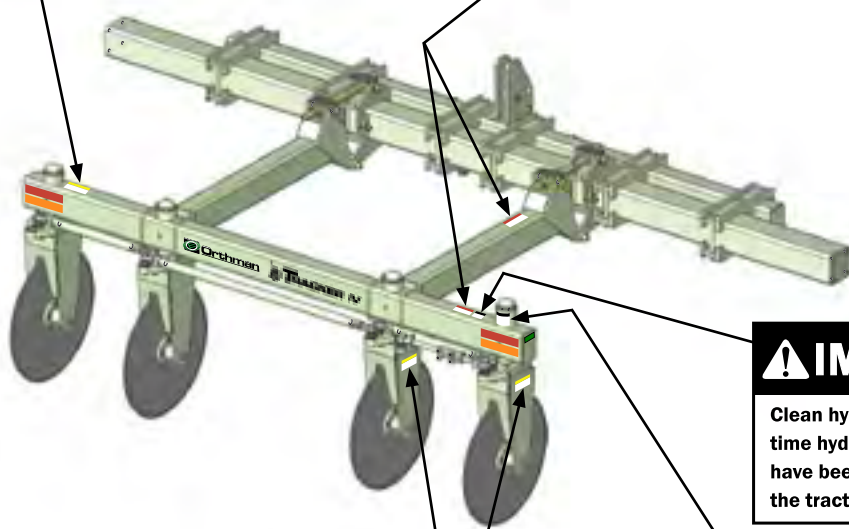

IMPORTANT

Clean hydraulic filter each time hydraulic connections have been disconnected from the tractor.

153-100

IMPORTANT

Consult Technical Manual or qualified dealer personnel before opening sensor housing.

153 - 099

CAUTION

Be extremely careful working around unshielded sharp edges. Injury may result from contact with sharp edges.

153 - 045

(1) per Tracker yoke and couler

IMPORTANT

Equipment operators should understand the enclosed manual before operating this equipment. Replacement manual, call 308-324-4654

Orthman Mfg., Inc. - 75765 Rd. 435 - Lexington, NE 68850

153-101

(manual enclosure)

IMPLEMENT GUIDANCE SYSTEM



MAJOR COMPONENT IDENTIFICATION

COMPONENT IDENTIFICATION

This component identification section is designed to familiarize the operator with the major components of the Tracker IV prior to installation or servicing of any implement components.

The majority of the Tracker IV is assembled at Orthman Mfg., Inc. To ensure safe and efficient transport from the manufacturer, various attachments may need to be installed upon delivery.

Tracker IV installation is illustrated and explained in the preparation and setup section of this manual. The preparation and set up section of this manual, provides generic installation information. Tracker IV's are available in numerous configurations thus the most prominent models are illustrated in the preparation and setup section. For a complete parts breakdown refer to the parts identification section of this manual.

Installation of optional attachments available to complement the Tracker IV are illustrated and explained in the optional attachments section of this manual.

CAUTION

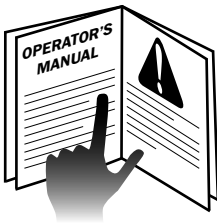

If Orthman implements are used in conjunction with the Tracker IV, be sure to read all operator manuals before attempting to operate any implement. Read and understand all operator manuals for machinery used in conjunction with the Tracker IV.

Before each use, check hardware for wear and proper torque. (pg. 0 - 0) Replace missing or damaged hardware with hardware of identical grade to restore implement to original specifications.

Reviewing this major component identification section very carefully will simplify both the installation of the Tracker IV. Follow sequential instructions in the preparation and setup section very carefully when installing the Tracker IV. Failure to do so can result in serious injury.



MAJOR COMPONENT IDENTIFICATION

HARDWARE COMPONENT IDENTIFICATION

TRACKER IV

 (4 Blade 30" model)

(tillage mounting scenario - straight mounting arms, allow for proper tillage toolbar height)

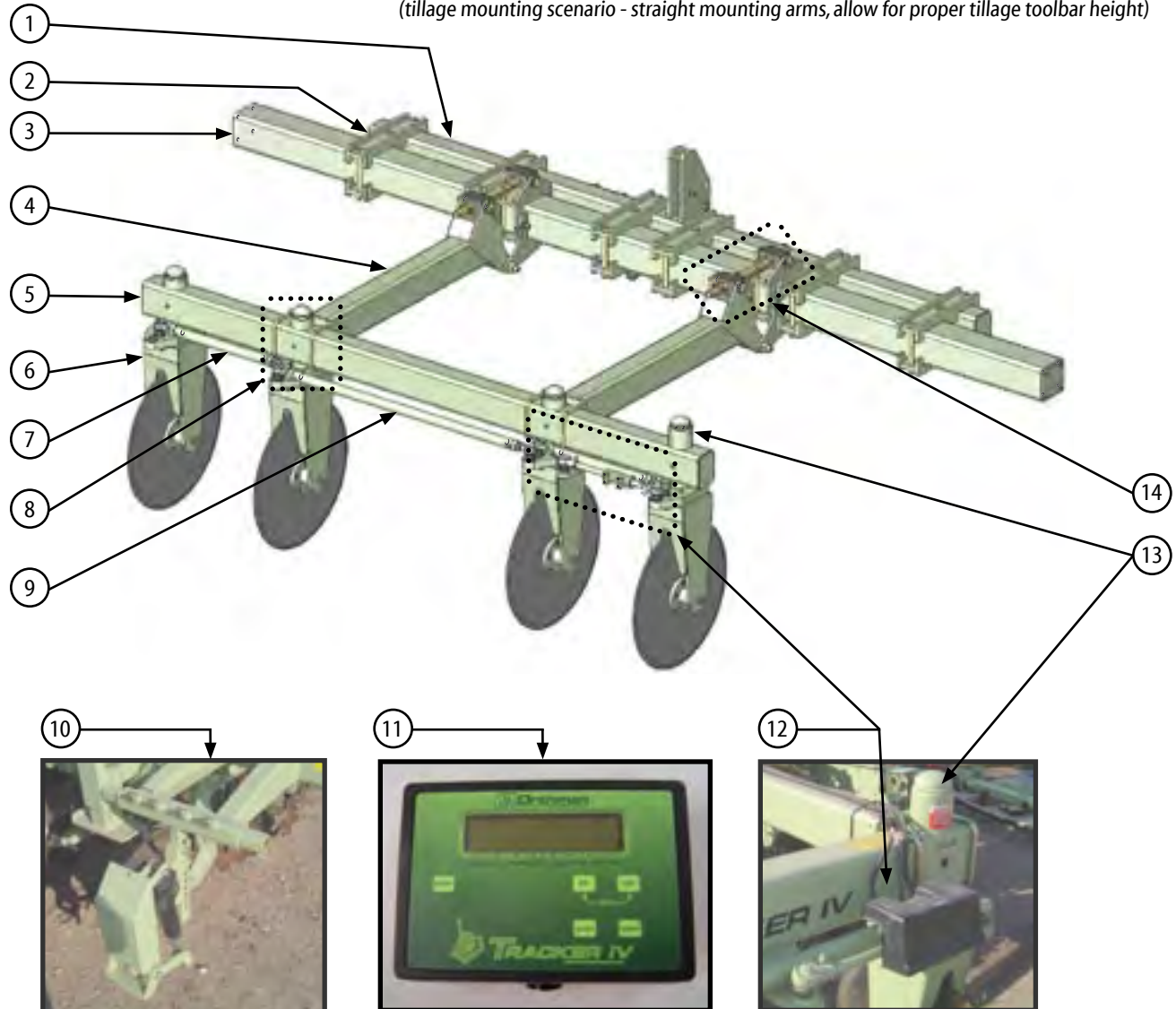

- | | |
|--|--|
| 1. Orthman 5 x 7 hitch | 8. Spindle (not visible) |
| 2. Hitch Clamp (4 pictured) | 9. Long Tie Rod (1 pictured) |
| 3. Orthman Toolbar (rigid) (primary implement toolbar) | 10. Probe Box (mounts to front of primary implement toolbar) |
| 4. Arm Mount Assembly (2) | 11. Console (mounts in tractor cab) |
| 5. Frame | 12. Manifold (covered with cowling) |
| 6. Yoke, Blade, and Hub Assembly (4 pictured) | 13. Feedback Sensor |
| 7. Short Tie Rod (2 pictured) | 14. Turnbuckle Assembly (steering blade depth adjustment) |

(component identification continued on following page)



MAJOR COMPONENT IDENTIFICATION

HARDWARE COMPONENT IDENTIFICATION

TRACKER IV (4 Blade 30" model)

(planter mounting scenario - angled mounting arms, allows for lower planter toolbar height)

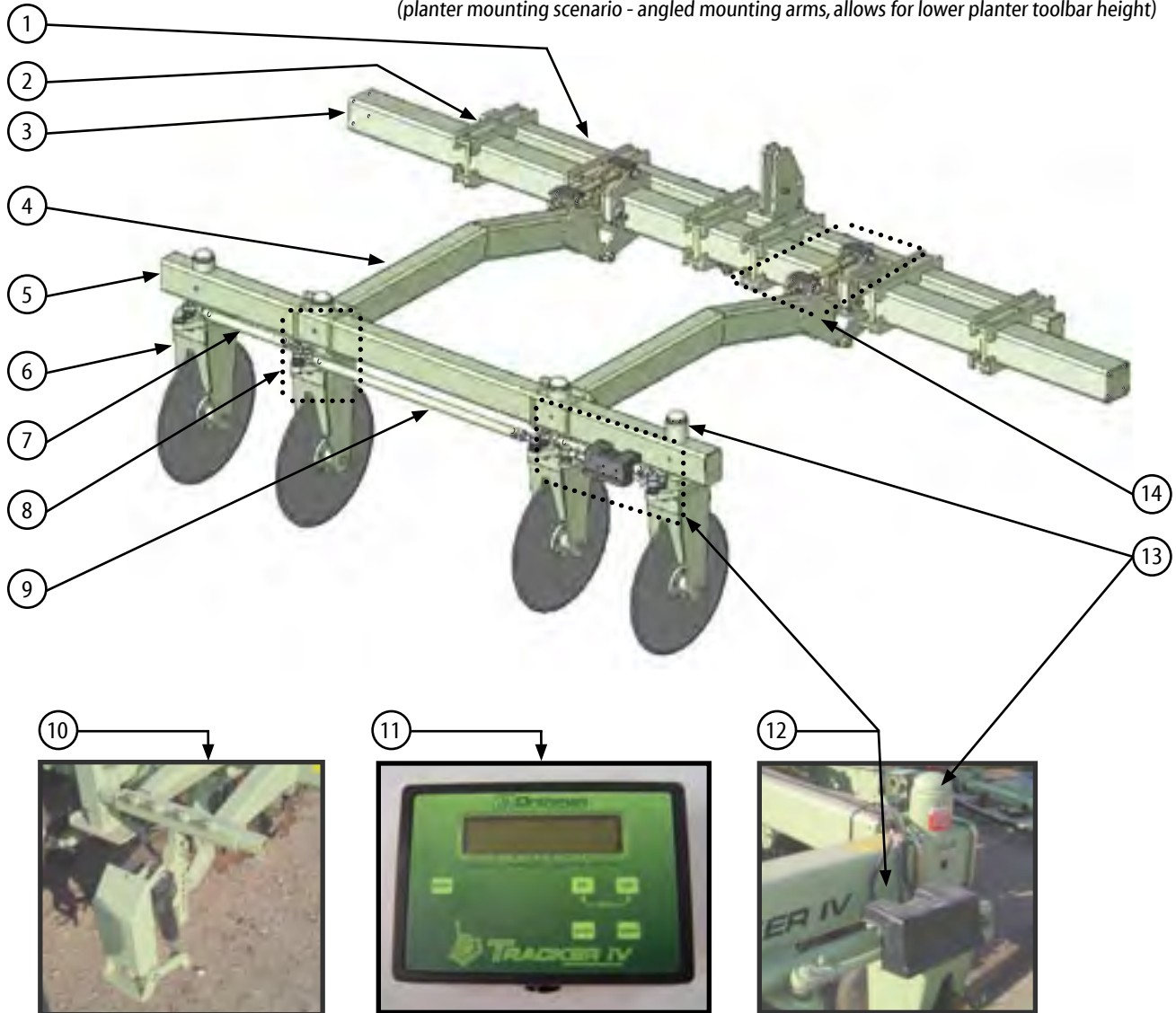

- 1. Orthman 5 x 7 hitch
- 2. Hitch Clamp (4 pictured)
- 3. Orthman Toolbar (rigid) (primary implement toolbar)
- 4. Arm Mount Assembly (2)
- 5. Frame
- 6. Yoke, Blade, and Hub Assembly (4 pictured)
- 7. Short Tie Rod (2 pictured)
- 8. Spindle (not visible)
- 9. Long Tie Rod (1 pictured)
- 10. Probe Box (mounts to front of primary implement toolbar)
- 11. Console (mounts in tractor cab)
- 12. Manifold (covered with cowling)
- 13. Feedback Sensor
- 14. Turnbuckle Assembly (steering blade depth adjustment)



MAJOR COMPONENT IDENTIFICATION

ELECTRICAL COMPONENT IDENTIFICATION

TRACKER IV

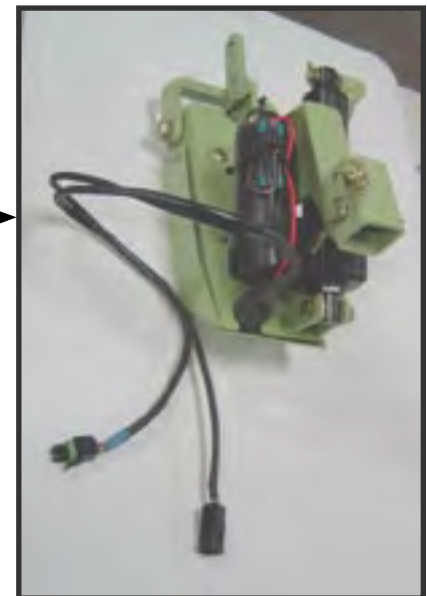
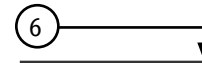
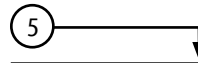
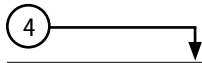
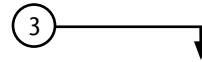
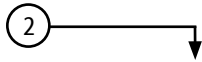
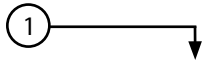

1. Console and Power Cable
2. Power Cable (not needed if using courtesy outlet in cab as power source into console)
3. Probe Box Extension Cable
4. Feedback Extension Cable
5. Extension Cable/Console Adapter Harness
6. Console
7. Probe Box

(electrical component identification continued on following page)



MAJOR COMPONENT IDENTIFICATION

ELECTRICAL COMPONENT ROUTING

TRACKER IV

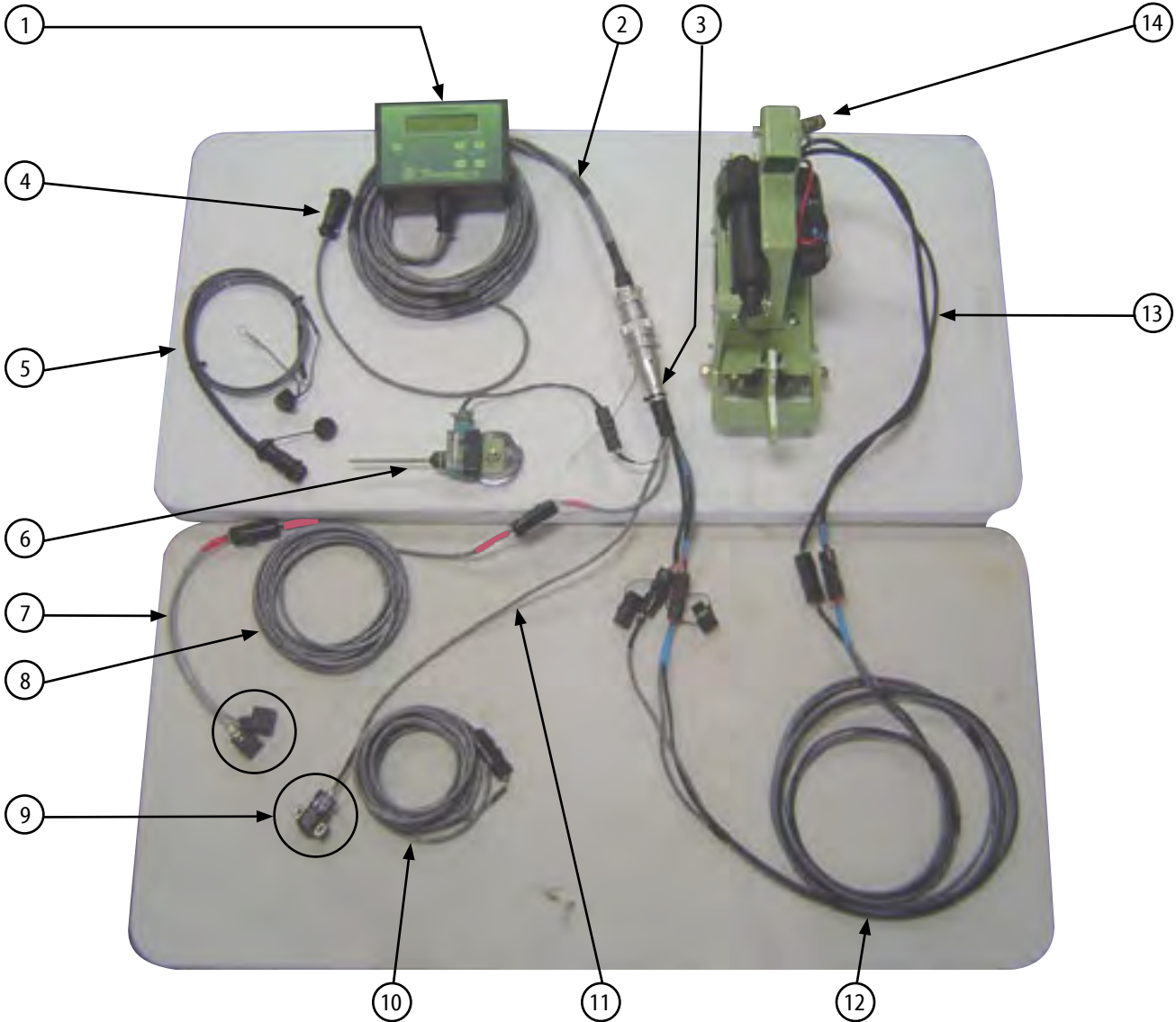

- 1. Console
- 2. Console and Power Cable
- 3. Extension Cable - Console Adapter Harness
- 4. Console Power Cable (to tractor cab courtesy outlet)
- 5. Console Power Cable (not needed if #3 above utilizes courtesy outlet)
(used if source of power to console is supplied with the tractor battery)
- 6. Lift Switch Magnet
- 7. Manifold Cable (circled ends attached to the manifold) (red ends)

- 8. Manifold Extension Cable (coiled up) (red ends)
- 9. Feedback Sensor (located inside of sensor housing)
- 10. Feedback Extension Cable (coiled up)
- 11. Feedback Cable
- 12. Probe Box Extension Cable (coiled up)
(when assembling, match blue to blue and black to black ends)
- 13. Probe Box Cable (black and blue ends)
- 14. Probe Box Assembly (will be mounted to the primary implement)



PREPARATION AND SETUP

MOUNTING ARM CLAMP TO TOOLBAR INSTALLATION



AVOID CRUSHING. Make sure all personnel are clear of the primary implement. Lower primary implement to the ground, place tractor in park, turn off engine, and remove key.

USE BAR STANDS TO SUPPORT THE PRIMARY IMPLEMENT. Park implement on a clean, dry, and level surface. An uneven surface could cause implement to shift or fall, resulting in injury or death, as well as implement damage. Securely support all implement components that must be raised. Remove buildup of grease, oil, or debris prior to installation of mounting arms.

Be extremely careful when installing mounting arms. Be sure to adequately support the weight of the hardware to avoid crushing. A lifting mechanism such as a crane, cherry picker, forklift, etc. will simplify the mounting arm installation process and reduce the chance of injury.

RECOMMENDED TOOLS: 1 1/8" wrenches and/or sockets.

1. Determine first the desired position of the mounting arms on the primary toolbar in accordance to the size and configuration of the Tracker IV.

NOTE: Tracker arm mounting position is illustrated on (pg. 0-0 and 0-0). These are typical mounting positions for 4 blade Trackers. Mounting is primarily dependent upon the configuration of the primary implement. If the Tracker include corner braces, be sure to mount the arms accordingly, allowing for ample Tracker frame area for corner brace mounting. Orthman hitch clamps may have to be moved to obtain optimum Tracker arm mounting position.

2. Make sure the Tracker mounting arms are equidistant from the center of the primary implement toolbar and when fully assembled, the u-bolts that mount the Tracker frame to the mount arms will not interfere with any of the Tracker spindle caps that protrude upward out of the Tracker frame.

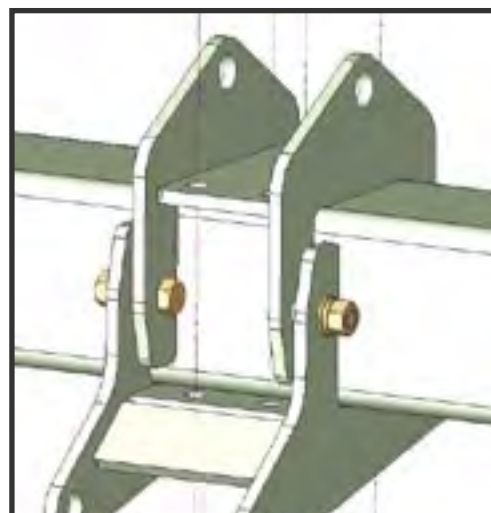
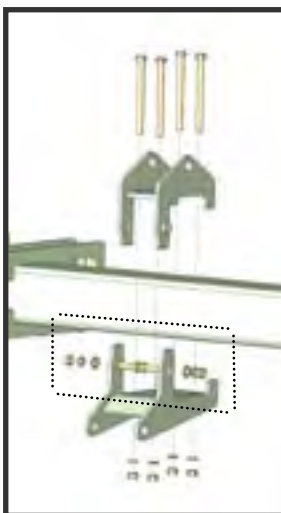

3. Place top and bottom clamps onto toolbar and slightly secure with (2) 2 1/2" bolts, flat washers, lock washers, and nuts. Do not fully tighten until clamp assembly is complete.



PREPARATION AND SETUP

MOUNTING ARM CLAMP TO TOOLBAR INSTALLATION

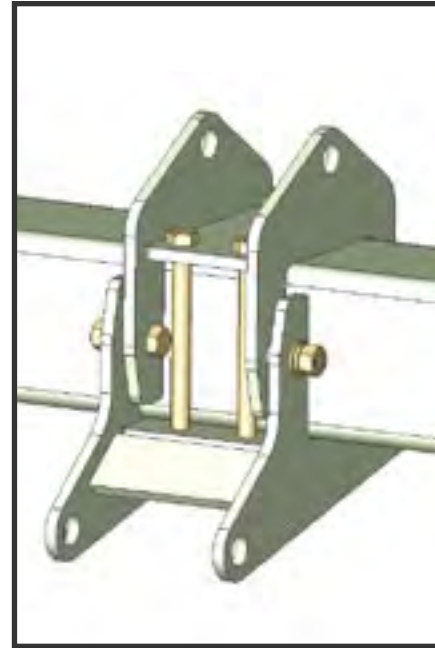
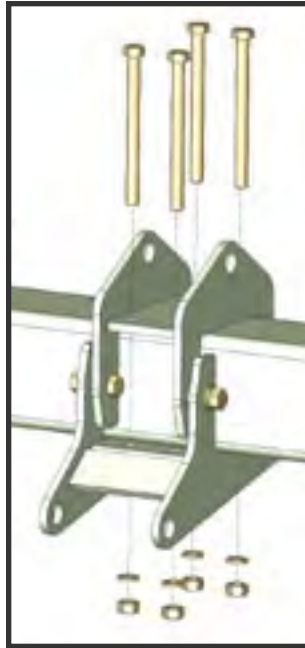

4. Align top and bottom clamp bolt holes in order to secure with (4) 9" bolts, lock washers, and nuts.
5. Tighten all (6) bolts and nuts to proper torque specifications. (pg. 0-0)
6. Repeat procedure to install the second of two mounting arm clamps.



PREPARATION AND SETUP

MOUNTING ARM CLAMP TO TOOLBAR AND 5X7 ORTHMAN HITCH INSTALLATION



AVOID CRUSHING. Make sure all personnel are clear of the primary implement. Lower primary implement to the ground, place tractor in park, turn off engine, and remove key.

USE BAR STANDS TO SUPPORT THE PRIMARY IMPLEMENT. Park implement on a clean, dry, and level surface. An uneven surface could cause implement to shift or fall, resulting in injury or death, as well as implement damage. Securely support all implement components that must be raised. Remove buildup of grease, oil, or debris prior to installation of mounting arms.

Be extremely careful when installing mounting arms. Be sure to adequately support the weight of the hardware to avoid crushing. A lifting mechanism such as a crane, cherry picker, forklift, etc. will simplify the mounting arm installation process and reduce the chance of injury.

RECOMMENDED TOOLS: 1 1/8" wrenches and/or sockets.

1. Determine first the desired position of the mounting arms on the primary toolbar in accordance to the size and configuration of the Tracker IV.

NOTE: Tracker arm mounting position is illustrated on (pg. 0-0 and 0-0). These are typical mounting positions for 4 blade Trackers. Mounting is primarily dependent upon the configuration of the primary implement. If the Tracker include corner braces, be sure to mount the arms accordingly, allowing for ample Tracker frame area for corner brace mounting. Orthman hitch clamps may have to be moved to obtain optimum Tracker arm mounting position.

2. Make sure the Tracker mounting arms are equidistant from the center of the primary implement toolbar and when fully assembled, the u-bolts that mount the Tracker frame to the mount arms will not interfere with any of the Tracker spindle caps that protrude upward out of the Tracker frame.

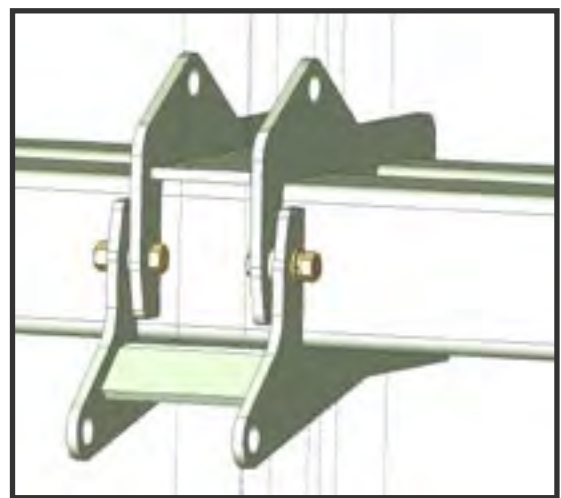
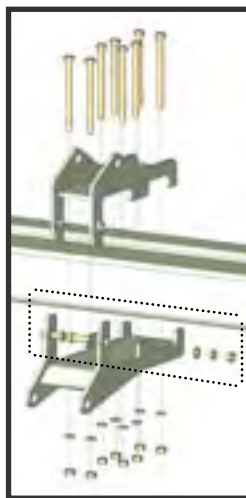

3. Place top and bottom clamps onto toolbar and slightly secure with (2) 2 1/2" bolts, flat washers, lock washers, and nuts. Do not fully tighten until clamp assembly is complete.



PREPARATION AND SETUP

MOUNTING ARM CLAMP TO TOOLBAR INSTALLATION

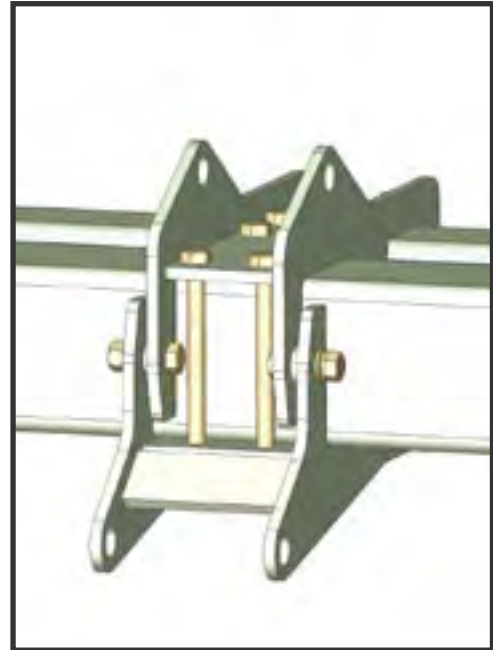
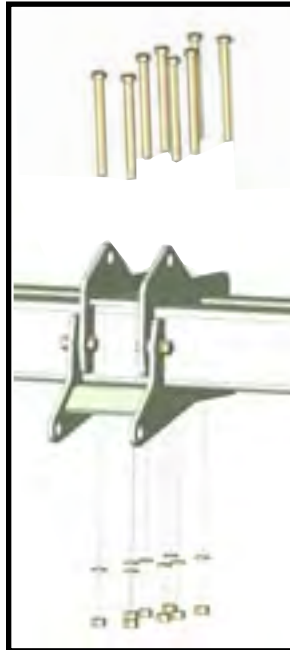

4. Align top and bottom clamp bolt holes in order to secure with (8) 9" bolts, lock washers, and nuts.
5. Tighten all (10) bolts and nuts to proper torque specifications. (pg. 0-0)
6. Repeat procedure to install the second of two mounting arm clamps.



PREPARATION AND SETUP

ARM TO CLAMP INSTALLATION



⚠ AVOID CRUSHING. Make sure all personnel are clear of the primary implement. Lower primary implement to the ground, place tractor in park, turn off engine, and remove key.

USE BAR STANDS TO SUPPORT THE PRIMARY IMPLEMENT. Park implement on a clean, dry, and level surface. An uneven surface could cause implement to shift or fall, resulting in injury or death, as well as implement damage. Securely support all implement components that must be raised. Remove buildup of grease, oil, or debris prior to installation of mounting arms.

Be extremely careful when installing mounting arms. Be sure to adequately support the weight of the hardware to avoid crushing. A lifting mechanism such as a crane, cherry picker, forklift, etc. will simplify the mounting arm installation process and reduce the chance of injury.

RECOMMENDED TOOLS: 1 7/8" wrenches and/or sockets.

1. Support the weight of the arm with a lifting mechanism such as a crane, cherry picker, forklift, etc.
2. Visually align the arm lower mounting holes and lower clamp holes.

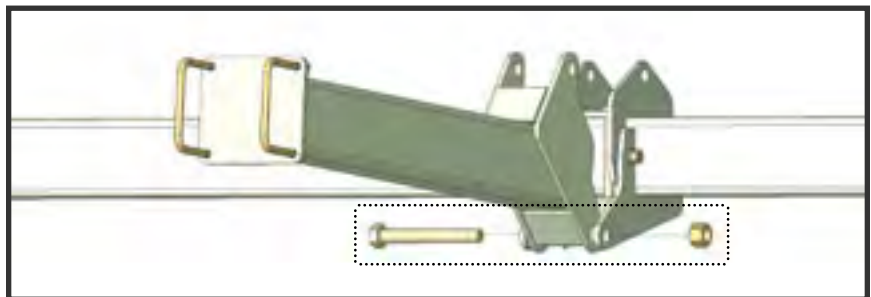

3. Insert bolt and tighten the self locking nut to a degree where no slop is present and the arm has the ability to pivot vertically.
4. Repeat the procedure to install the second of two arms.



PREPARATION AND SETUP

TURNBUCKLE INSTALLATION



⚠ AVOID CRUSHING. Make sure all personnel are clear of the primary implement. Lower primary implement to the ground, place tractor in park, turn off engine, and remove key.

USE BAR STANDS TO SUPPORT THE PRIMARY IMPLEMENT. Park implement on a clean, dry, and level surface. An uneven surface could cause implement to shift or fall, resulting in injury or death, as well as implement damage. Securely support all implement components that must be raised. Remove buildup of grease, oil, or debris prior to installation of turnbuckles.

Be extremely careful when installing turnbuckles. Be sure to adequately support the weight of the arms to avoid crushing. A lifting mechanism such as a crane, cherry picker, forklift, etc. will simplify the turnbuckle installation process and reduce the chance of injury.

RECOMMENDED TOOLS: 1 1/2" wrenches and/or sockets.

1. Support the rear end weight of the arm with a lifting mechanism such as a crane, cherry picker, forklift, etc.
2. Make sure that the arm is able to pivot vertically before installing the turnbuckle. Adjustment of the turnbuckle length allows for depth adjustment of the steering blades.

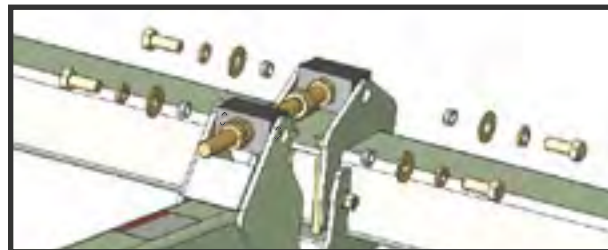
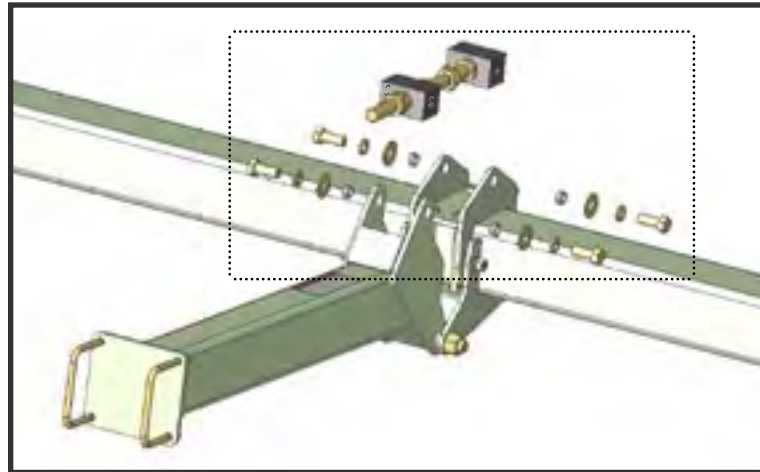

3. Place the turnbuckle as pictured above in order that the upper mounting holes of the clamp and arm visually line up with the turnbuckle. In order to achieve the proper alignment, the height of the rear of the arm may have to be vertically altered.



PREPARATION AND SETUP

TURNBUCKLE INSTALLATION

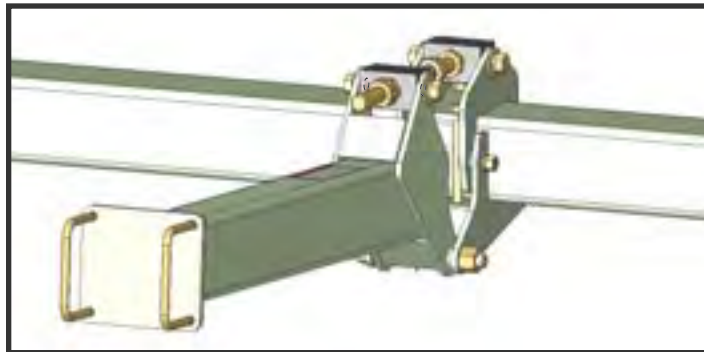
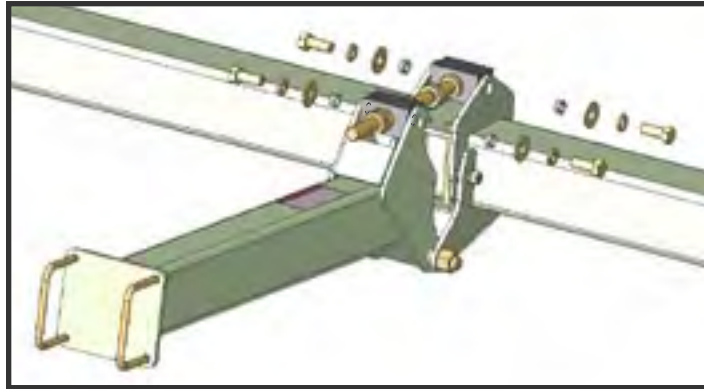

4. APPLY LOCTITE TO THE (4) BOLTS PICTURED ABOVE BEFORE PROCEEDING TO INSTALL THE TURNBUCKLE.
5. Insert the (4) bushings into the upper clamp and upper arm mounting holes.
6. Install (4) flat washers, lock washers, and bolts as pictured above. Tighten to torque specifications. (pg.0 - 0)
7. Repeat procedure to install the second of two turnbuckles.

NOTE: The turnbuckle used on 1800 and 1900 Toolbars utilize a urethane damper pictured below. Installation of the 1800/1900 turnbuckle pictured below is the same as the standard turnbuckle installation outlined in the above instruction.



CUSHION TURNBUCKLE ASSEMBLY
(standard on 1800 and 1900 Toolbars)
(optional on all other Trackers)
Cushion Turnbuckle assembly part # 333-318



PREPARATION AND SETUP

BLADE AND HUB ASSEMBLY



⚠ AVOID CRUSHING. Make sure all personnel are clear of the primary implement. Lower primary implement to the ground, place tractor in park, turn off engine, and remove key.



USE BAR STANDS TO SUPPORT THE PRIMARY IMPLEMENT. Park implement on a clean, dry, and level surface. An uneven surface could cause implement to shift or fall, resulting in injury or death, as well as implement damage. Securely support all implement components that must be raised. Remove buildup of grease, oil, or debris prior to blade and hub assembly.

⚠ CAUTION
Be extremely careful working around unshielded sharp edges. Injury may result from contact with sharp edges. 153 - 045

Be extremely careful when assembling blades and hubs. It is recommended to assemble the blades and hubs in an area removed from the primary implement and tracker clamps and arms to reduce the risk of implement shift that could result in injury. Assemble all blade and hub assemblies before proceeding with the following preparation and setup instructions.

RECOMMENDED TOOLS: 3/4" wrenches and/or sockets.

1. Physically place the blade in a vise or similar mechanism that will hold the blade securely before attempting to install the hub, spacer, and nuts.

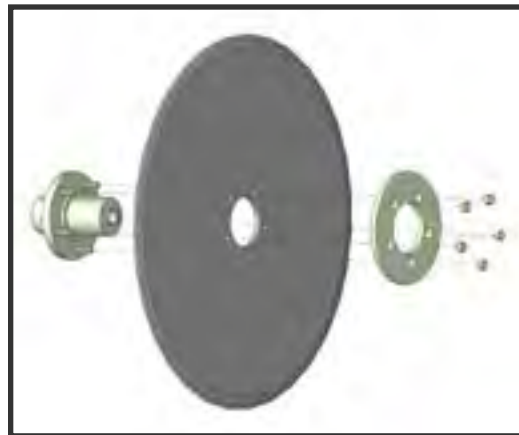

⚠ CAUTION
Be extremely careful working around unshielded sharp edges. Injury may result from contact with sharp edges. 153 - 045

2. Align the five bolt holes on the blade, hub, and spacer.
3. Thread the five bolts through the blade, hub, and spacer. Secure with five nuts.
4. Be sure to evenly tighten the bolts and nuts to torque specifications. (pg. 0 - 0)
5. Repeat procedure for all remaining blade and hub assemblies.



PREPARATION AND SETUP

YOKE TO FRAME INSTALLATION



⚠ AVOID CRUSHING. Make sure all personnel are clear of the primary implement. Lower primary implement to the ground, place tractor in park, turn off engine, and remove key.

USE BAR STANDS TO SUPPORT THE PRIMARY IMPLEMENT. Park implement on a clean, dry, and level surface. An uneven surface could cause implement to shift or fall, resulting in injury or death, as well as implement damage. Securely support all implement components that must be raised. Remove buildup of grease, oil, or debris prior to installation of yokes.

Be extremely careful when installing yokes. Be sure to adequately support the weight of the Tracker frame to avoid crushing. A lifting mechanism with height adjustment such as a crane, cherry picker, forklift, etc. will simplify the yoke installation process and reduce the chance of injury.

RECOMMENDED TOOLS: 1 1/8" socket with extension or deep well socket and air gun.

1. Adequately support the weight of the Tracker frame to a height that will allow for installation of the yoke assemblies.

(it is highly recommended to support the weight of the Tracker frame with additional supporting devices if the lifting mechanism were to fail)

2. Align the yoke assembly bolt holes with the four bolt holes on the bottom side of the spindle.

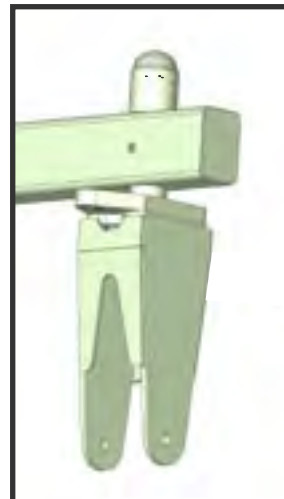
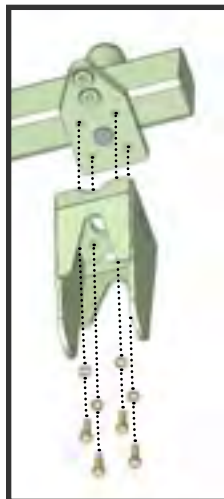

3. Utilize (4) lock washers and bolts to secure the yoke to the spindle mount.

4. Tighten all hardware to proper torque specifications. (pg. 0 - 0)

5. Repeat installation of remaining yoke assemblies.

(When all yoke assemblies are mounted to the Tracker frame, raise entire assembly to a height that will allow for installation of hub and blade assemblies. Once desired height is achieved, support the weight of the Tracker frame and yokes with additional supporting devices.)



PREPARATION AND SETUP

BLADE AND HUB TO YOKE INSTALLATION

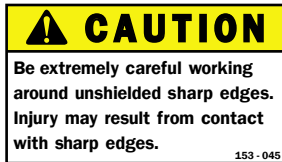

AVOID CRUSHING. Make sure all personnel are clear of the primary implement. Lower primary implement to the ground, place tractor in park, turn off engine, and remove key.

USE BAR STANDS TO SUPPORT THE PRIMARY IMPLEMENT. Park implement on a clean, dry, and level surface. An uneven surface could cause implement to shift or fall, resulting in injury or death, as well as implement damage. Securely support all implement components that must be raised. Remove buildup of grease, oil, or debris prior to installation of blade and hub assemblies.

Be extremely careful when installing blade and hub assemblies. Be sure to adequately support the weight of the Tracker frame and yoke assembly to avoid crushing. A lifting mechanism with height adjustment such as a crane, cherry picker, forklift, etc. will simplify the yoke installation process and reduce the chance of injury.

CAUTION: Wear hand protection when installing the blade and hub assemblies. Handling of the blade will be required for installation. Hand protection will reduce the chance of injury.

RECOMMENDED TOOLS: 1 1/2" wrenches and/or sockets

1. Adequately support the weight of the Tracker frame and yoke assembly to a height that will allow for installation of the blade and hub assemblies.
(it is highly recommended to support the weight of the Tracker frame with additional supporting devices if the lifting mechanism were to fail)
2. Align fork bolt holes with hole through center of hub.

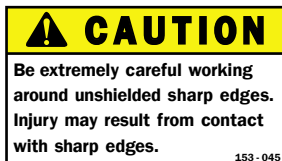
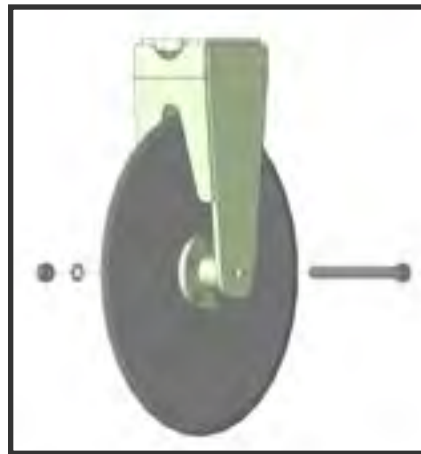

3. Secure blade and hub assembly to the yoke with bolt, lock washer, and nut.
4. Tighten to proper torque specifications. (pg. 0 - 0)
5. Repeat installation procedure for remaining blade and hub assemblies.



PREPARATION AND SETUP

FRAME TO ARM INSTALLATION TYPICAL CULTIVATOR SCENARIO



⚠ AVOID CRUSHING. Make sure all personnel are clear of the primary implement. Lower primary implement to the ground, place tractor in park, turn off engine, and remove key.

USE BAR STANDS TO SUPPORT THE PRIMARY IMPLEMENT. Park implement on a clean, dry, and level surface. An uneven surface could cause implement to shift or fall, resulting in injury or death, as well as implement damage. Securely support all implement components that must be raised. Remove buildup of grease, oil, or debris prior to installation of the Tracker frame.

Be extremely careful when installing the Tracker frame. Be sure to adequately support the weight of the Tracker frame to avoid crushing. A lifting mechanism with height adjustment such as a crane, cherry picker, forklift, etc. will simplify the frame installation process and reduce the chance of injury.

The illustration below is typical mounting scenario when the Tracker is being utilized with a tillage tool such as a cultivator. Positioning of the mounting arms is often determined by vacant area on the primary implement toolbar. It is imperative that wherever the mounting arms are located, they are equidistant from the center of the primary implement toolbar in order to operate correctly.

If optional braces are included with your Tracker, take mounting the braces into consideration before installing the Tracker frame. Make sure before installing Tracker frame there is adequate mounting space available for the additional braces.

RECOMMENDED TOOLS: 1 1/8" wrenches and/or sockets.

1. Adequately support the weight of the Tracker frame to a height that will allow for mounting to the mounting arms.
(it is highly recommended to support the weight of the Tracker frame with additional supporting devices if the lifting mechanism were to fail)
2. Align either set of mounting arm bolt holes with the top and bottom sides of the Tracker frame 5 x 7 toolbar.

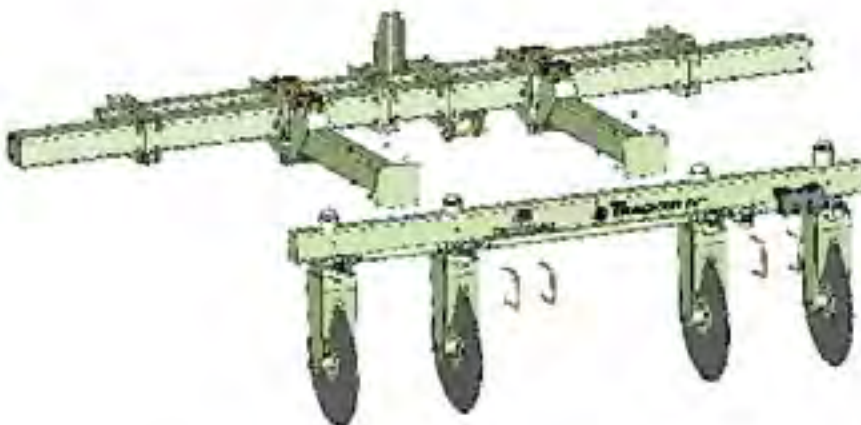

3. Mount the Tracker frame to the mounting arms with (4) u-bolts, (8) lock washers and (8) nuts.
4. Tighten all hardware to the proper torque specifications. (pg. 0 - 0)



PREPARATION AND SETUP

FRAME TO ARM INSTALLATION TYPICAL PLANTER SCENARIO



⚠ AVOID CRUSHING. Make sure all personnel are clear of the primary implement. Lower primary implement to the ground, place tractor in park, turn off engine, and remove key.

USE BAR STANDS TO SUPPORT THE PRIMARY IMPLEMENT. Park implement on a clean, dry, and level surface. An uneven surface could cause implement to shift or fall, resulting in injury or death, as well as implement damage. Securely support all implement components that must be raised. Remove buildup of grease, oil, or debris prior to installation of the Tracker frame.

Be extremely careful when installing the Tracker frame. Be sure to adequately support the weight of the Tracker frame to avoid crushing. A lifting mechanism with height adjustment such as a crane, cherry picker, forklift, etc. will simplify the frame installation process and reduce the chance of injury.

The illustration below is typical mounting scenario when the Tracker is being utilized with a planter. Positioning of the mounting arms is often determined by vacant area on the planter toolbar. It is imperative that wherever the mounting arms are located, they are equidistant from the center of the primary implement toolbar in order to operate correctly.

If optional braces are included with your Tracker, take mounting the braces into consideration before installing the Tracker frame. Make sure before installing Tracker frame there is adequate mounting space available for the additional braces.

RECOMMENDED TOOLS: 1 1/8" wrenches and/or sockets.

1. Adequately support the weight of the Tracker frame to a height that will allow for mounting to the mounting arms.
(it is highly recommended to support the weight of the Tracker frame with additional supporting devices if the lifting mechanism were to fail)
2. Align the yoke mounting arm bolt holes with the top and bottom sides of the Tracker frame 5 x 7 toolbar.

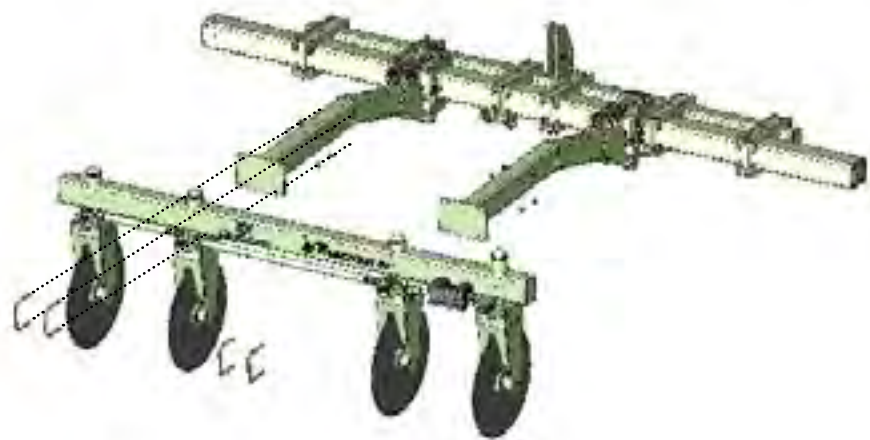

3. Mount the Tracker frame to the mounting arms with (4) u-bolts, (8) lock washers and (8) nuts.
4. Tighten all hardware to the proper torque specifications. (pg. 0 - 0)



PREPARATION AND SETUP

PROBE BOX INSTALLATION



AVOID CRUSHING. Make sure all personnel are clear of the primary implement. Lower primary implement to the ground, place tractor in park, turn off engine, and remove key.



USE BAR STANDS TO SUPPORT THE PRIMARY IMPLEMENT. Park implement on a clean, dry, and level surface. An uneven surface could cause implement to shift or fall, resulting in injury or death, as well as implement damage. Securely support all implement components that must be raised. Remove buildup of grease, oil, or debris prior to installation of the Probe Box.

Be extremely careful when installing the Probe Box. Be sure to adequately support the weight of the Probe Box assembly to avoid possible injury.



IT IS NOT RECOMMENDED TO MOUNT THE PROBE BOX TO A WING SECTION OF A STACKING OR FOLDING TOOLBAR. IT IS ALWAYS RECOMMENDED TO MOUNT THE PROBE BOX TO THE CENTER SECTION OF THE PRIMARY TOOLBAR.

RECOMMENDED TOOLS: 1 1/8" and 3/4" wrenches and/or sockets.

5/8" - 12pt end or 1/2" open end wrench for set bolts.

1. Mount the extension mounting arms to the front of the primary toolbar with (2) u-bolts, (4) lockwashers, and (4) nuts.

NOTE: Do not fully tighten. It is recommended to be able to physically manipulate the position of the extension mounting arms.



2. Loosen set bolts and jam nuts on arms and probe box tube. (t-shaped weld assembly)

3. Slide probe box brace through arm, probe box tube, and remaining arm.

NOTE: Do not tighten. Adjustment and measuring will be required before tightening.





PREPARATION AND SETUP

PROBE BOX INSTALLATION



RECOMMENDED TOOLS: 1 1/8" and 3/4" wrenches and/or sockets.

5/8" - 12pt end or 1/2" open end wrench for set bolts.

4. Maneuver arms, brace, and probe box tube in order that your arms are in a position that will not interfere with any primary implement toolbar components.

NOTE: Once the assembly is in a position that is acceptable to the producer, make sure the brace is centered, the probe box tube is centered, and the arms are equidistant from the center of the probe box tube. Pictured below are three acceptable mounting scenarios. Your mounting configuration may or may not reflect the images below.

Once you are satisfied with the position of the components, tighten all hardware (u-bolts, set screws, and jam nuts) to proper torque specifications. (pg. 0 - 0)





PREPARATION AND SETUP

PROBE BOX INSTALLATION



RECOMMENDED TOOLS: 1 1/8" and 3/4" wrenches and/or sockets.

5. Physically slide probe box assembly up and onto the probe box tube and secure with pin with hair pin cotter pin as pictured below.

NOTE: At this point, use any of the pin holes approximately 1/2 up the probe box tube. Further depth adjustment of the probe box assembly will be required after input device (ex. probe balls or feeler rods) are installed.

6. Utilize set bolt and jam nut to secure probe box to probe box tube.
Do not overtighten, further adjustment will be necessary.





PREPARATION AND SETUP

FEELER ROD INSTALLATION



RECOMMENDED TOOLS: 10MM wrenches and/or sockets.

6MM wrenches and/or sockets.

1. Determine the desired position of the feeler rod in relationship to the block.

(See illustrations below - 3 configurations)

Mount feeler rods in desired position with (4) 6MM bolts, lock washers, and nuts.

Tighten to torque specifications (pg.0 - 0)

Be sure if set in the free vertical pivot position, the feeler rod is independent of the block.

NOTE: The "A" dimension in the illustration below should be 1" wider than the row spacing of the crop. When mounting the feeler rods and blocks to the angle iron, make sure the "A" dimension is 1" greater than the crop spacing. I.E. 30" crop spacing - 31" feeler rod spacing.

LH Rod and Block (view from top)



Free Vertical Pivot Position



Fixed Position



Fixed Position

2. Use (2) 10MM bolts and nuts to mount the feeler rod assembly to the probe box.

(See illustrations below - hardware circled)

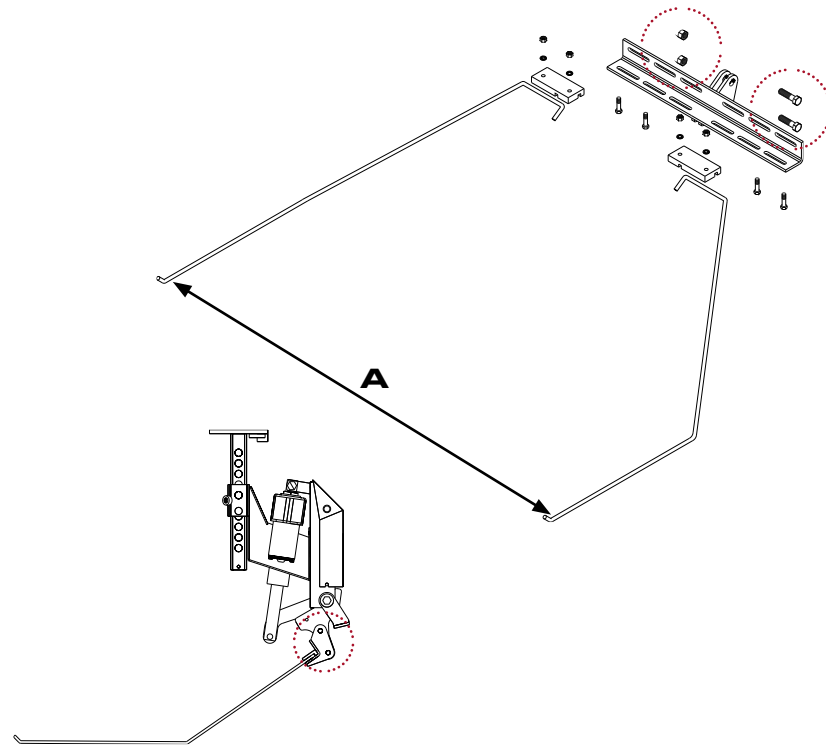

3. Tighten all hardware to proper torque specifications. (pg.0 - 0)



PREPARATION AND SETUP

DOUBLE IN-LINE PROBE BALL INSTALLATION



RECOMMENDED TOOLS: 10MM wrenches and/or sockets.

NOTE: Refer to Parts Identification section for Double In-Line Probe Ball assembly drawing.

1. Use (2) 10MM bolts and nuts to mount the probe ball assembly to the probe box.
(See illustrations below - hardware circled)

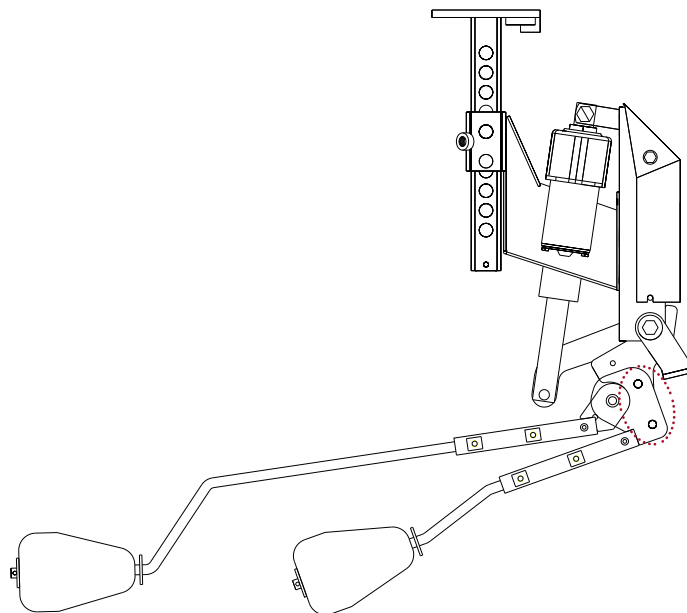
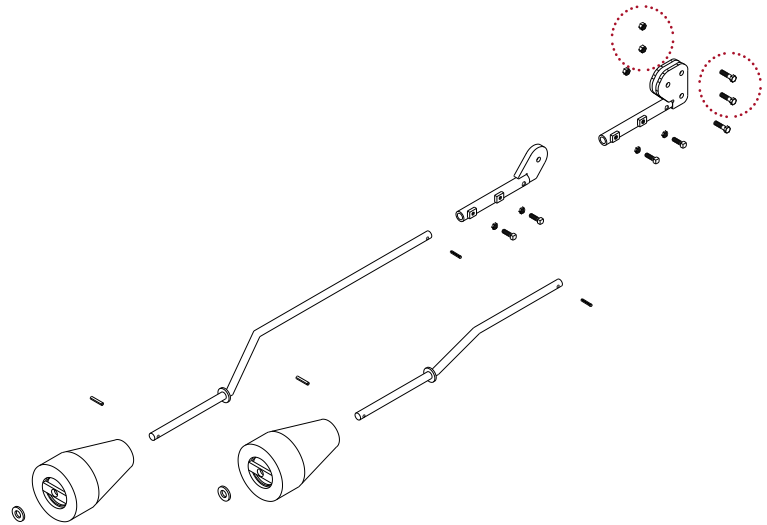

2. Tighten all hardware to proper torque specifications. (pg.0 - 0)



PREPARATION AND SETUP

TRIPLE PROBE BALL INSTALLATION

RECOMMENDED TOOLS: 10MM wrenches and/or sockets.

NOTE: Refer to Parts Identification section for Triple Probe Ball assembly drawing.

1. Use (2) 10MM bolts and nuts to mount the triple probe ball assembly to the probe box.
(See illustrations below - hardware circled)



NOTE: Long center following rod not illustrated.

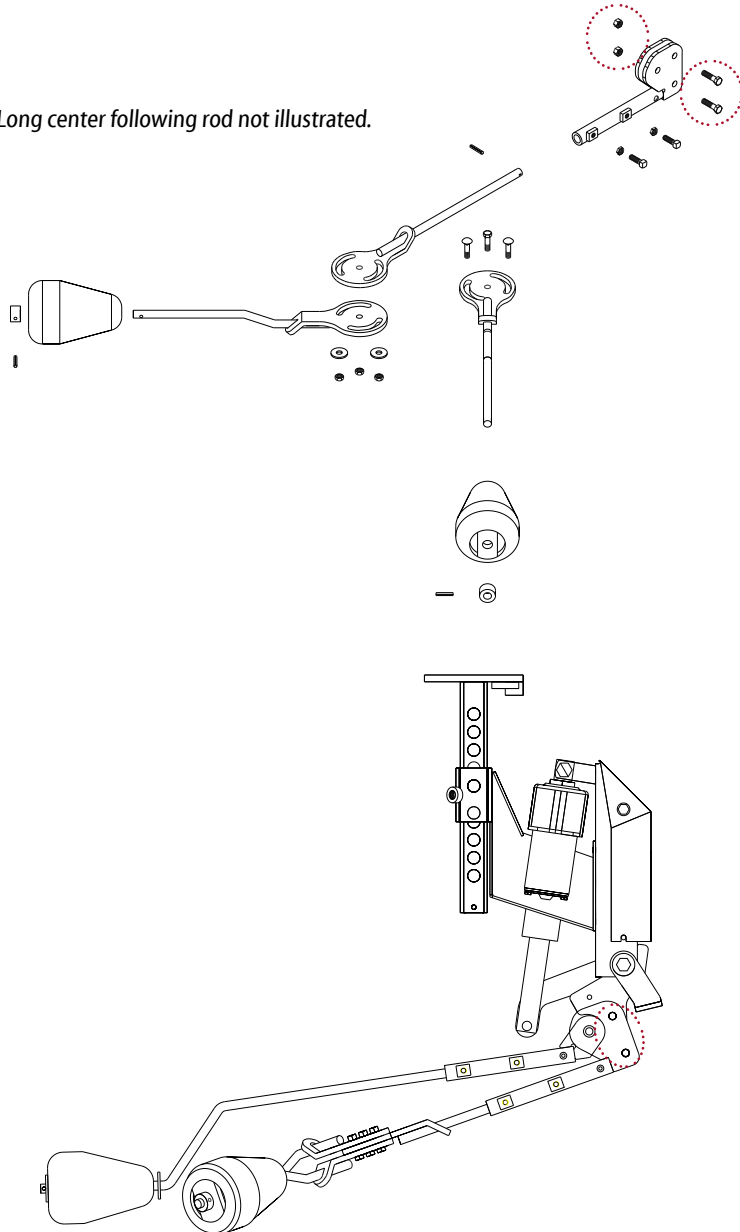

2. Tighten all hardware to proper torque specifications. (pg. 0 - 0)



PREPARATION AND SETUP

HYDRAULIC COMPONENT INSTALLATION



Escaping pressurized hydraulic fluid can penetrate skin, resulting in injury or death. Relieve hydraulic system pressure before connecting or disconnecting tractor. Use cardboard or wood, **NOT BODY PARTS**, to check for suspected leaks. Wear protective gloves and safety glasses or goggles when working with hydraulic systems. If an accident occurs, see a doctor immediately for proper treatment.

	⚠ DANGER
	HIGH-PRESSURE FLUID HAZARD
	To prevent serious injury or death:
	• Relieve pressure on hydraulic system before servicing or disconnecting hoses.
	• Wear proper hand and eye protection when searching for leaks. Use wood or cardboard instead of hands.
	• Keep all components in good repair.
	<small>153-528</small>

1. Use phillips head screwdriver to remove black cowlng to expose the manifold assembly.



RECOMMENDED TOOL: 5/8" open end wrench.

NOTE: All folding, rigid, and stacker toolbars will utilize part # 196-245 (264" length hoses) 1800 Series toolbars utilizing a Tracker IV will utilize part # 196-142 (468" length hoses)

2. Install 7/16 FJX ends of both hoses to the pressure and return ports on the manifold assembly. (the manifold assembly is stamped with a "P" and an "R" to notate pressure and return)

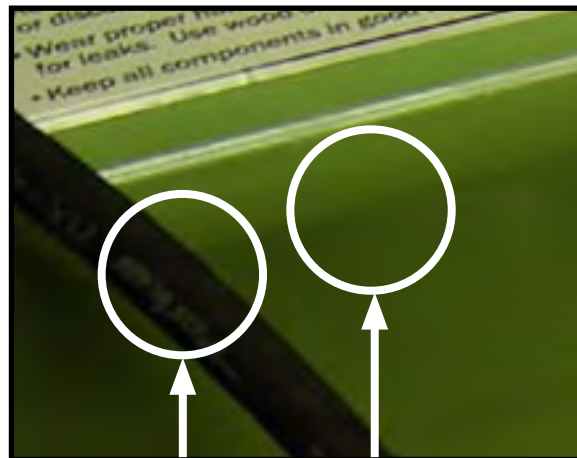

Return

Pressure

3. Route and secure both hoses to the RH Tracker arm.
4. Hook hose ends up to respective return and pressure tractor outlets.
5. Install black manifold cowlng to protect manifold from elements.



PREPARATION AND SETUP

ELECTRICAL COMPONENT ROUTING

Install all cables as illustrated below. The layout below obviously does not include the Tracker implement, but all connections and components are identified. Once you have located and identified all of the equipment below, it is advisable to assemble as pictured below to familiarize yourself with the components. Proceed to route and adhere all cables to the implement in an appropriate fashion to avoid damage to the equipment.

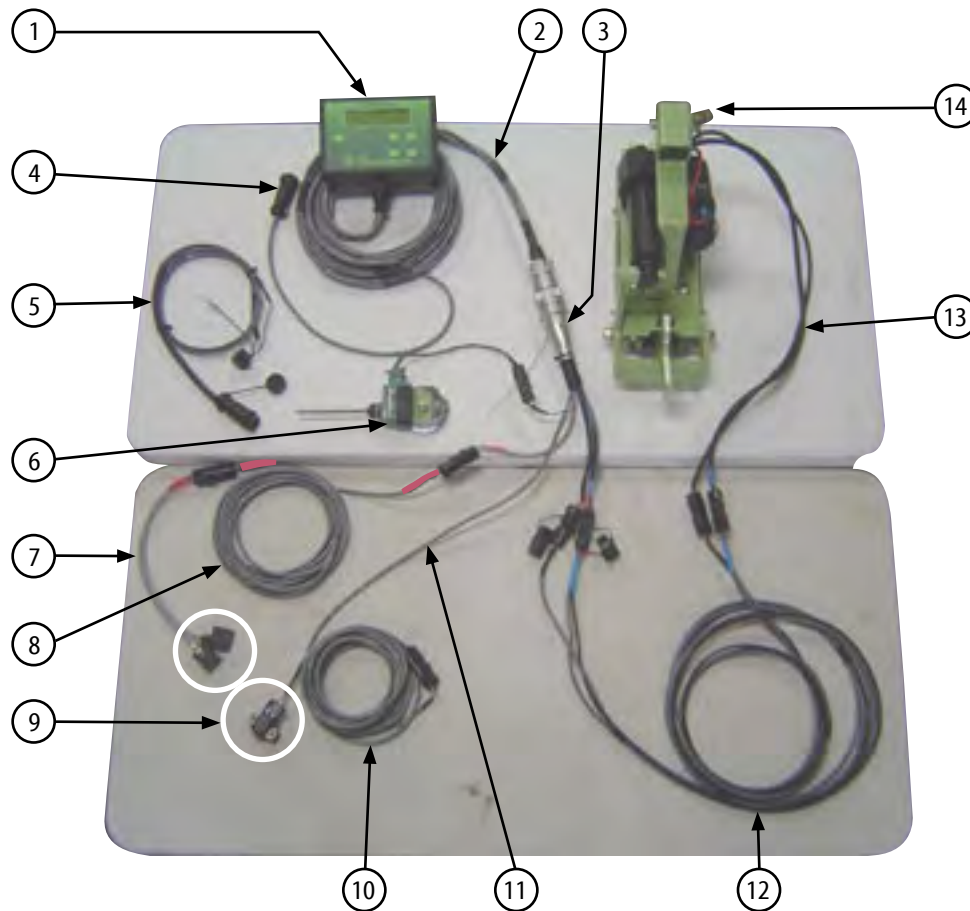

- | | |
|---|--|
| 1. Console | 8. Manifold Extension Cable (coiled up) (red ends) |
| 2. Console and Power Cable | 9. Feedback Sensor (located inside of sensor housing) |
| 3. Extension Cable - Console Adapter Harness | 10. Feedback Extension Cable (coiled up) |
| 4. Console Power Cable (to tractor cab courtesy outlet) | 11. Feedback Cable |
| 5. Console Power Cable (not needed if #3 above utilizes courtesy outlet)
(used if source of power to console is supplied with the tractor battery) | 12. Probe Box Extension Cable (coiled up)
(when assembling, match blue to blue and black to black ends) |
| 6. Lift Switch Magnet | 13. Probe Box Cable (black and blue ends) |
| 7. Manifold Cable (circled ends attached to the manifold) (red ends) | 14. Probe Box Assembly (will be mounted to the primary implement) |



PREPARATION AND SETUP

PROBE LIFT SWITCH INSTALLATION



! Be extremely careful when designating a feasible mounting position for the probe lift switch. The probe lift switch is often mounted in an area that will allow for the tractor hitch to trip the switch and in order to test the position of the switch and the activation, movement of the tractor hitch is necessary. When testing to locate a position for the switch be sure that all personnel is clear of all implement. Serious injury can result due to various crushing points are present when implement is raised and lowered.

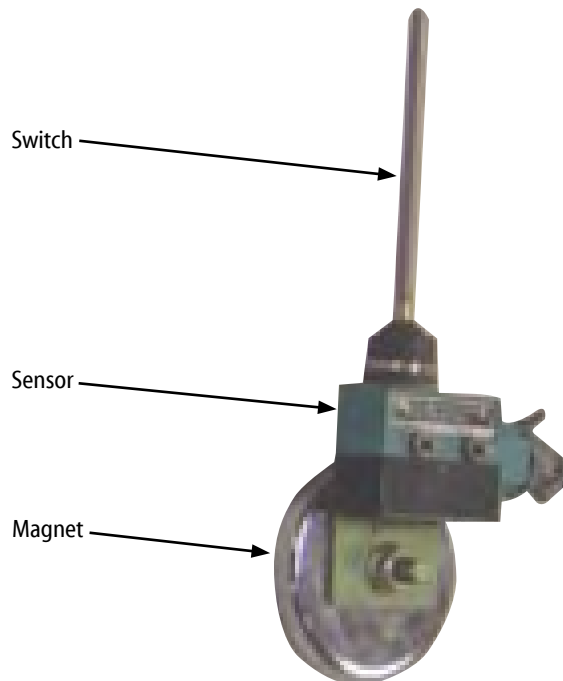

The probe lift switch is a device designed to lift the probe (*input device i.e. probe balls or feeler rods*) at the same time the operator chooses to raise the primary implement out of the ground. The lift switch is equipped with a magnet for easy and multiple mounting capabilities. When the switch is altered from the position illustrated above the sensor will prompt the probe box to lift the input device. When the switch is returned to the position illustrated above the sensor will prompt the probe box to lower the input device.

The mounting position of the probe lift switch is strictly operator preference.



FIELD SETTINGS

TRACKER BLADE DEPTH ADJUSTMENT



Once the implement has been moved to the desired field, the first adjustment will be the depth at which the Tracker Steering Blades operate. The Tracker Steering Blades should engage the soil enough to adequately steer the implement but must also be operating at a depth that will not submerge the blade hub into the soil to avoid premature wear.

NOTE: The correct tractor SCV must be engaged such that the correct hose is pressurized otherwise the Tracker will not be supplied with the hydraulic oil pressure that is required to pivot the steering blades and steer the implement.

As the tractor hitch is lowered to the field position, the system will automatically switch from standby to autosteer mode and display the probe position. The probe mechanism will also be lowered at this time if the probe lift switch is located in a proper position. When the hitch is lifted the system will automatically center the Tracker blades as well as lift the probing mechanism if the probe lift switch is in a proper position. *(if this feature is not working correctly, refer to pg. 0 - 0 for probe lift switch installation instructions)*

Once the implements are lowered to the ground, proceed to pull the tractor slowly forward and make all adjustments needed to attain the proper position of the primary implement. When making primary implement adjustments, ignore all facets of the Tracker IV. Tracker IV adjustments will be made after the primary implement is set to operate correctly.

Assuming all adjustments have been made to the primary implement and the operator is satisfied with the performance of the machine, we will proceed to adjust the operational depth of the Tracker blades.

Manipulation of the turnbuckle will provide the operational depth adjustment of the Tracker IV blades. Adjustment of the turnbuckle is outlined on the following pages. The illustration below is for reference only as a good preliminary depth.

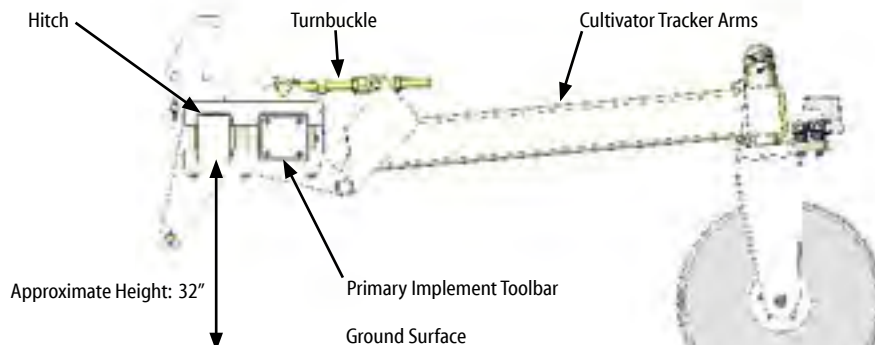



TRACKER BLADE DEPTH ADJUSTMENT

Operational depth of the Tracker blades will differ with soil conditions. Typically, the previous and below illustrations illustrate a good depth to start with. Loose soils may require a greater operational depth and harder soils can allow the blades to operate relatively shallow. The depth of the blades is determined by the ability of the steering blades to adequately guide the primary implement to operator satisfaction. It is not advisable to submerge the blade hub into the soil. Submerging the hub in the soil could cause premature wear of hub components.

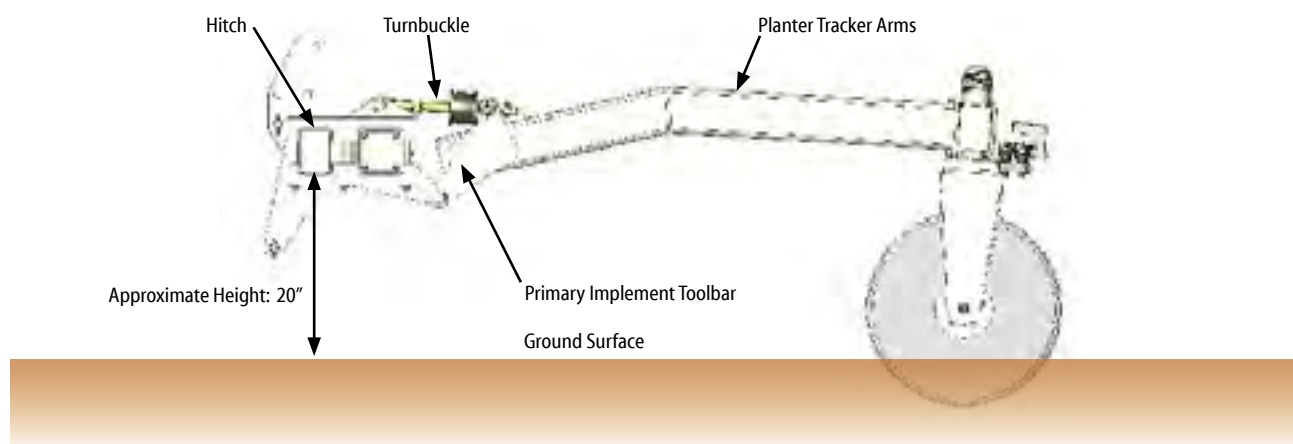

The two illustrations below outline the maximum and minimum operational depths of the Tracker blades. The illustration on the left would entail some soft soils where the Tracker blades require more surface area to soil contact in order to adequately steer the primary implement. The illustration on the right could possibly be in some harder soils where minimal contact with the soil will still allow the Tracker blades to steer the implement to operator specifications. Overall, the operational depth of the Tracker blades is dependent on operator/owner preference.

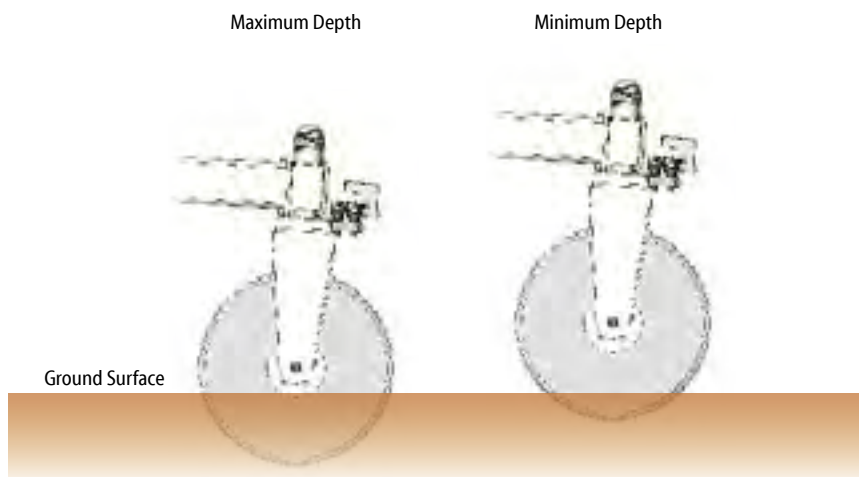



FIELD SETTINGS

TRACKER BLADE DEPTH ADJUSTMENT



As stated earlier, essentially to adjust the Tracker blade operational depth, adjustments are made to both of the Tracker arm turnbuckle assemblies. Lengthening the turnbuckle allows the blade to further penetrate the soil and shortening the turnbuckle does not allow the Tracker blades to penetrate as deeply.

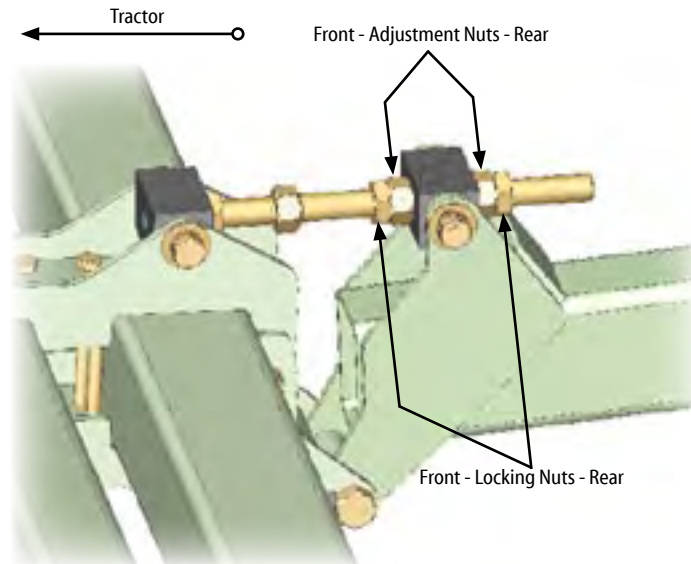

RECOMMENDED TOOLS: 2 1/16" open end wrench and/or large crescent wrench.

NOTE: Both the Tracker turnbuckles must be adjusted to the same length. Make sure after adjustment is made the distance between the turnbuckle blocks are the same for both assemblies. A lifting mechanism attached to the Tracker frame will alleviate weight placed on the turnbuckle assemblies and allow for easier adjustment. If a lifting mechanism is not available, using the resistance of the actual soil to relieve pressure also will allow for easier adjustment.

1. Determine whether the turnbuckle assembly needs to be lengthened or shortened due to the application and current depth of the blades.
NOTE: Increasing distance between the turnbuckle blocks will increase operating depth. Decreasing distance between the turnbuckle blocks will decrease operating depth.
2. If it is determined that the assembly needs to be shortened: loosen both the front locking nut and adjustment nut. Use rear adjustment to shorten distance between blocks. Measure and repeat procedure on adjacent Tracker turnbuckle assembly. If it is determined that the assembly needs to be lengthened: loosen both the rear locking and adjustment nut. Use front adjustment nut to lengthen distance between block. Measure and repeat procedure on adjacent Tracker turnbuckle assembly.
3. Repeat step 2 until the Tracker blades operate at a depth that will suffice for the soil conditions and optimum steering of the implement.
4. Tighten both adjustment nuts to the rear block and then tighten both jam nuts to the adjustment nuts. Tighten to torque specifications. (pg. 0 - 0)



FIELD SETTINGS

PROBING DEVICE DEPTH ADJUSTMENT



Place the implement in the field in the field position. Make sure the probe lift switch is working properly. At this point the probe lift switch should appear as below, prompting the probe box to have lowered the probing device.

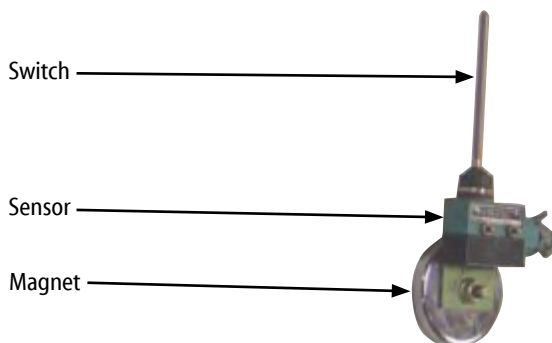

Stop tractor, place in park, stop engine and dismount to make adjustments.

1. Determine the proper operational depth of the probing device from the illustrations below.

Probe Balls

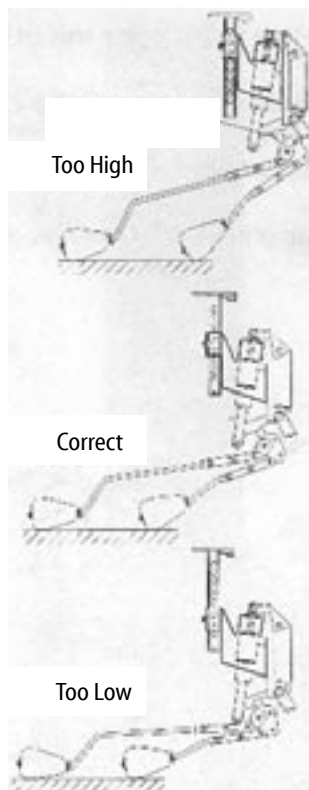

Feeler Rods

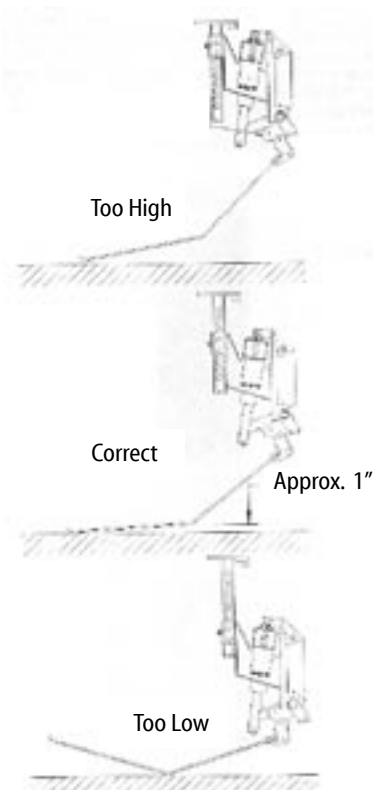



FIELD SETTINGS

PROBING DEVICE DEPTH ADJUSTMENT

RECOMMENDED TOOLS: 1 1/8" and 3/4" wrenches and/or sockets.

2. Loosen jam nut and set bolt to allow for vertical adjustment.
3. Remove hair pin cotter pin from pin and physically support the weight before removing pin.
4. Remove pin and adjust vertically until correct height is determined and secure vertically with pin and hair pin cotter pin.
5. Continue to repeat above procedures until proper position is achieved and then secure with set bolt and jam nut.





POWERING UP THE CONSOLE



The Orthman Tracker is calibrated at the factory and is ready for field operation after tractor installation.

1. Engage the hydraulic remote and power up the console by pressing the power switch on the face of the console.

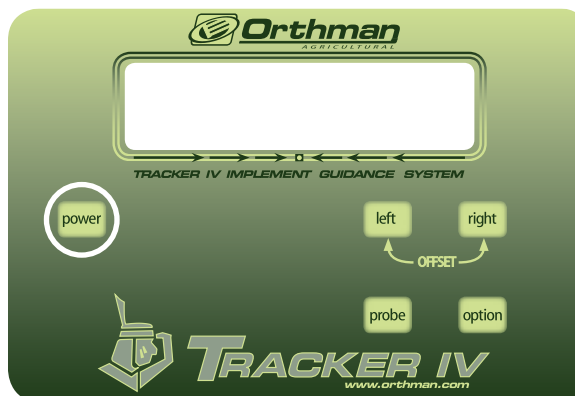

The Tracker is now ready for operation. As the tractor hitch is lowered to the field position, the system will automatically switch from standby to autosteer mode and display the probe position on the console window. The probing device and probe box will also lower at this time.

When the hitch is raised to the transport position, the system will automatically center the Tracker blades and will switch to standby mode while displaying the blade position. The probing device and probe box will also automatically be raised at this time as well.

2. The Tracker is activated by pressing the Probe button or deactivated by pressing the Probe button again.

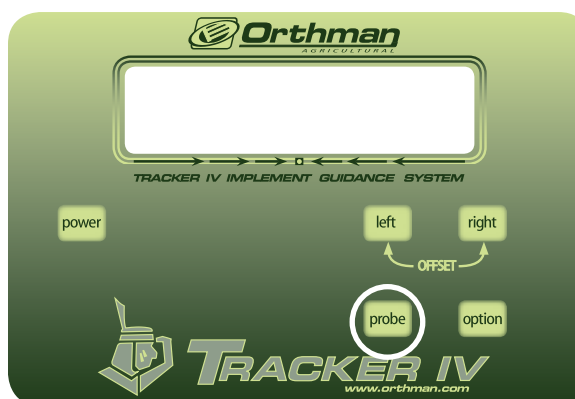



FIELD SETTINGS

LEFT AND RIGHT OFFSET



The implement can be manually offset from the row sensing probing device by pressing the Offset Left or Right buttons on the console face. This feature lets the operator manually shift the position of the implement. This feature is often used to straighten rows or adjust a guess row. To remove the Offset, press the opposite Offset button the same number of times or simply press both Offset buttons at the same time and the Tracker will proceed to gather input information from the probing device.

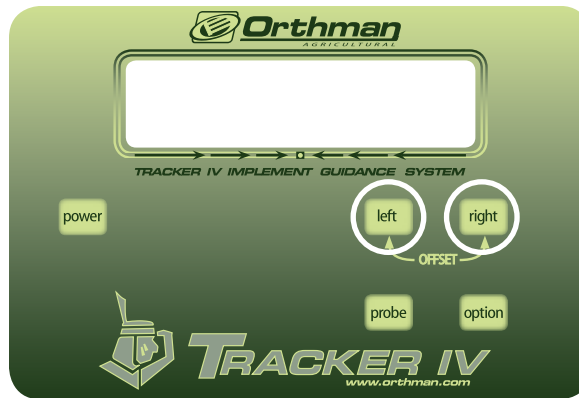

The Option button on the console face allows the operator to enter the on-screen adjustment mode which is described in the following "Performance Settings" section of the manual. The Option button also allows the operator to review a list of troubleshooting suggestions when an error message is displayed on screen. Refer to the "Troubleshooting" section of the manual for more information.

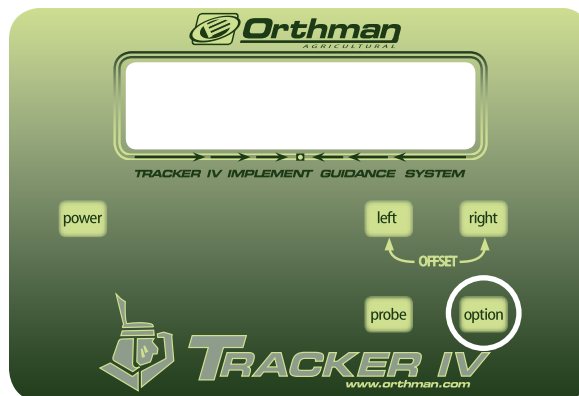



PERFORMANCE SETTINGS

BASIC PERFORMANCE SETTINGS



The Tracker is configured to take the guess work out of the system by setting key parameters at the factory to ensure the system performs well for the new operator when initially taking the Tracker to the field. The basic performance settings consist of the:

1. Steering Amplifier
2. Sensor Ratio
3. System Gain
4. Probe Averaging

These basic performance settings are able to be accessed and modified while in operation in the field in order that the operator can modify the settings while the machine is in motion and the results of the modifications can readily be seen and deemed acceptable or unacceptable dependent upon the field conditions.

While in motion: press the OPTION key and hold down for approximately 4-5 seconds to access the basic performance settings. Pressing the OPTION button will scroll through the options.

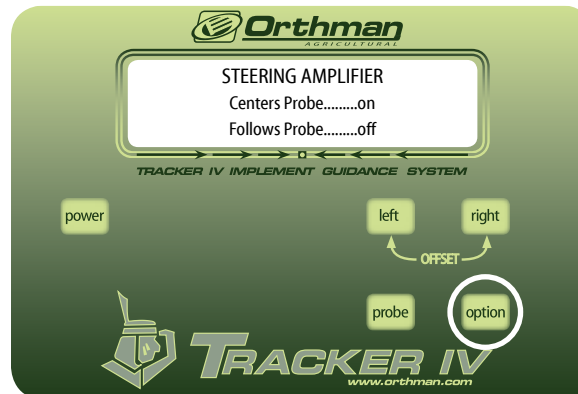

1. STEERING AMPLIFIER PERFORMANCE SETTING

- Steering Amplifier (default setting - off)
In the default setting, the blades will react to the probe position changes. As the probing device moves off of center, the blades will move off of center.
- Steering Amplifier (on)
When the steering amplifier is on, the blades will maintain any position necessary to keep the probe in the centered position. As the probe moves off of center, the blades will continue to correct until the probe returns to center where it will stop.

NOTE: The steering amplifier is an advantageous feature when on side hills and on contours.



PERFORMANCE SETTINGS

BASIC PERFORMANCE SETTINGS



The Tracker is configured to take the guess work out of the system by setting key parameters at the factory to ensure the system performs well for the new operator when initially taking the Tracker to the field. The basic performance settings consist of the:

- 1. Steering Amplifier
- 2. Sensor Ratio
- 3. System Gain
- 4. Probe Averaging

These basic performance settings are able to be accessed and modified while in operation in the field in order that the operator can modify the settings while the machine is in motion and the results of the modifications can readily be seen and deemed acceptable or unacceptable dependent upon the field conditions.

While in motion: press the OPTION key and hold down for approximately 4-5 seconds to access the basic performance settings. Pressing the OPTION button will scroll through the options.

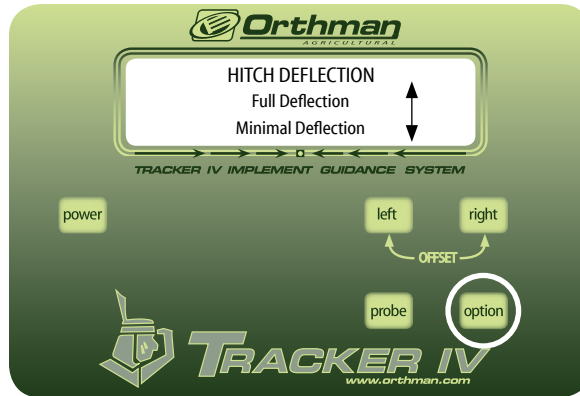

2. SENSOR RATIO SETTING

The sensor ratio is the magnitude of the blade movement in relationship to the position of the probes. At full deflection the blades will move fully when the probe is at its extreme. The full deflection can be turned down to minimal deflection the blades will only move partially when the probe is at its extreme. By manipulating the sensor ratio the operator can change the degree the blades will pivot in relationship to the input information.

- Sensor Ratio (default setting - full deflection - “turned up”)

In the full deflection setting the blades move fully when the probe is at its extreme. When the probe is at its extreme, the blades will also move fully.
- Sensor Ratio (minimal deflection - “turned down”)

In the minimal deflection setting the blades move slightly when the probe is at its extreme. When the probe is at its extreme, the blades will react to a minimal amount.

NOTE: The sensor ratio is often turned down in the planting or bedding operations to assist with building straight rows due to the blades not reacting fully to the input information from the probing device.



PERFORMANCE SETTINGS

BASIC PERFORMANCE SETTINGS



The Tracker is configured to take the guess work out of the system by setting key parameters at the factory to ensure the system performs well for the new operator when initially taking the Tracker to the field. The basic performance settings consist of the:

1. Steering Amplifier
2. Sensor Ratio
3. System Gain
4. Probe Averaging

These basic performance settings are able to be accessed and modified while in operation in the field in order that the operator can modify the settings while the machine is in motion and the results of the modifications can readily be seen and deemed acceptable or unacceptable dependent upon the field conditions.

While in motion: press the OPTION key and hold down for approximately 4-5 seconds to access the basic performance settings. Pressing the OPTION button will scroll through the options.

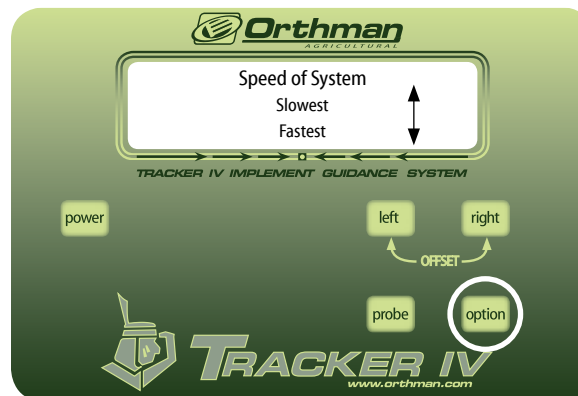

3. SYSTEM GAIN SETTING

The system gain setting allows the operator to slow down or speed up the reaction time of the blades in relationship to the input information being provided by the probing device. The factory setting is in the middle of the scale allowing for the adjustment of reaction time to be either sped up or slowed down.

- System Gain (default setting - medium)
- Sensor Gain ("turned up")
When the sensor gain is turned up the reaction of the Tracker blades to the input information will be virtually simultaneous.
- Sensor Gain ("turned down")
When the system gain is turned down the reaction of the Tracker blades to the input information is delayed to maintain a straighter path.

NOTE: System gain is often slowed down in planting and bedding operations to promote a straighter row and is sped up in the cultivation scenario to follow the crop precisely.



PERFORMANCE SETTINGS

BASIC PERFORMANCE SETTINGS



The Tracker is configured to take the guess work out of the system by setting key parameters at the factory to ensure the system performs well for the new operator when initially taking the Tracker to the field. The basic performance settings consist of the:

1. Steering Amplifier
2. Sensor Ratio
3. System Gain
4. Probe Averaging

These basic performance settings are able to be accessed and modified while in operation in the field in order that the operator can modify the settings while the machine is in motion and the results of the modifications can readily be seen and deemed acceptable or unacceptable dependent upon the field conditions.

While in motion: press the OPTION key and hold down for approximately 4-5 seconds to access the basic performance settings. Pressing the OPTION button will scroll through the options.

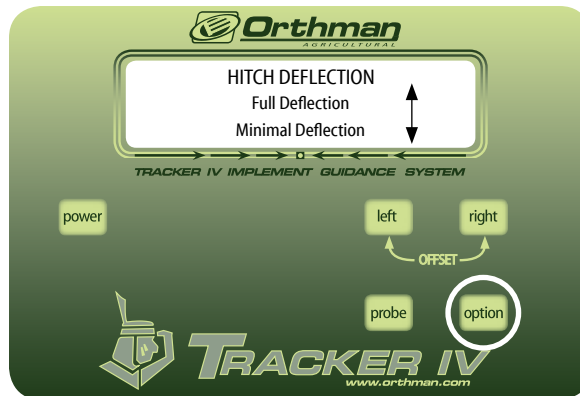

4. PROBE AVERAGING SETTING

Probe averaging allows the operator to manipulate the effect that field obstructions such as large clods, standing corn stalks, or other uncharacteristic obstructions in a particular field have on the movement of the Tracker blades.

- Probe Averaging (default setting - off)

In the off setting, if the probing device were to encounter an unforeseen obstruction in the field, the probe would come into contact and the Tracker blades would react to the probe information causing a shift in the implement position.

- Probe Averaging (turned on - 1, 1.5, 2.0 second increment choices)

When activated, if the probing device were to encounter an unforeseen obstruction in the field, the probe would come into contact and due to the averaging, the Tracker blades would not react due to the input being drawn on an average position. When activating the probe averaging you may choose between 1, 1.5, or 2.0 seconds to average the probing position.

NOTE: The probe averaging is often times turned on to improve stability of the Tracker and reduce sudden implement correction in the planting and bedding scenarios to promote a



PERFORMANCE SETTINGS

UTILITY FUNCTIONS



Additional utility functions of the console can be accessed by holding down the OPTION button during the powering up of the console. These additional functions are not accessible during active control mode. You will not be able to access the utility functions while in motion.

Utility functions: 1. Filter Hours 2. Reset Filter Hours 3. Probe Delay 4. Manual Steer

The console must be powered off to exit the utility functions.

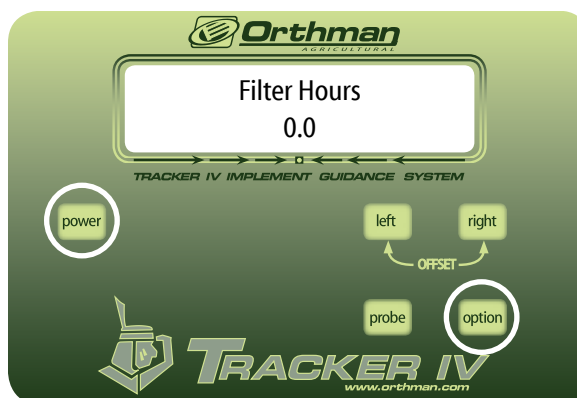

1. MONITOR FILTER HOURS

This function displays the current number of hours the hydraulic filter has been in operation since the last cleaning or replacement. When 100 hours have been accumulated, the controller will display a “clean filter” message during the powering up routine.

NOTE: After the hydraulic filter has been either cleaned or replaced, the operation hours can be reset to zero in the following RESET FILTER HOURS utility function. (see illustration below)

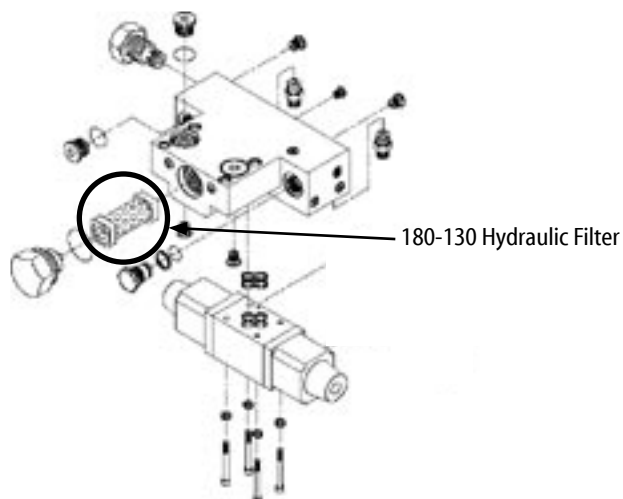



PERFORMANCE SETTINGS

UTILITY FUNCTIONS



Additional utility functions of the console can be accessed by holding down the OPTION button during the powering up of the console. These additional functions are not accessible during active control mode. You will not be able to access the utility functions while in motion.

Utility functions: 1. Filter Hours 2. Reset Filter Hours 3. Probe Delay 4. Manual Steer

The console must be powered off to exit the utility functions.

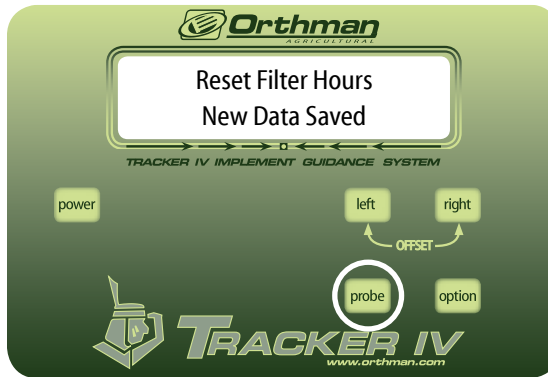

2. RESET FILTER HOURS

To reset the filter timer to 0.0 hours after either replacing or cleaning the hydraulic filter, push and hold the PROBE button for 10 seconds. A successful reset of operation hours to 0.0 will be signaled with a bee and a "New Data Saved" message on the lower line of the console window.

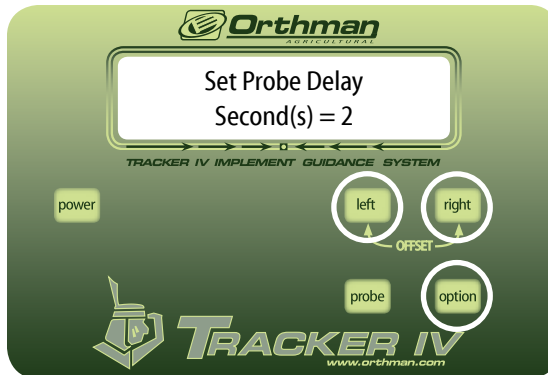

3. PROBE DELAY

A delay in the time the lift switch signals the implement has been lowered to the time the Tracker responds to the input device position is set at 2 seconds from the factory. The amount of probe delay can be adjusted by using the LEFT and RIGHT OFFSET buttons to vary the value from 0 to 10 seconds. Pressing the OPTION button will save the new setting.



PERFORMANCE SETTINGS

UTILITY FUNCTIONS



Additional utility functions of the console can be accessed by holding down the OPTION button during the powering up of the console. These additional functions are not accessible during active control mode. You will not be able to access the utility functions while in motion.

Utility functions: 1. Filter Hours 2. Reset Filter Hours 3. Probe Delay 4. Manual Steer

The console must be powered off to exit the utility functions.



4. MANUAL STEER

The Tracker can be manually steered by depressing the LEFT and RIGHT OFFSET buttons. This feature allows the operator to manually control the position of the implement.



TROUBLESHOOTING

SYSTEM STATUS ERROR CODES



The Orthman Tracker IV is designed to aid in the troubleshooting of problems as they occur during field operation. The constant monitoring of the system status and also allowing the operator to enter a field service diagnostic mode that offers 26 diagnostic modes.

During typical field operation the Tracker will constantly monitor itself for errors. If an error is encountered, the console will display one of the following error messages on the bottom line of the console display. Initially the console will alarm three times and continue to display the message until the error is resolved. While the error is being displayed the OPTION button can be pressed and an explanation of the error code will scroll across the display.

After the explanation of the error code has scrolled across the screen, the display will read: "Help 1 of X." The letter X stands for the number of help messages available pertaining to that particular error message.

Press the OPTION button within 5 seconds to display the first help message. Each time thereafter, the OPTION button is pressed, a different help message will be displayed. After a help message is finished scrolling across the screen, the OPTION button must be pressed again within 5 seconds to view the next help message, otherwise the display will revert back to the original error message.

ERROR MESSAGE

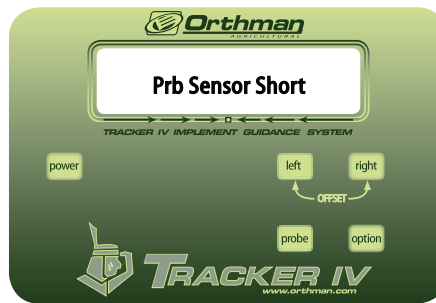

PROBLEM and HELP

PROBLEM:
The Probe Sensor signal is shorted to ground.

- HELP SUGGESTIONS:**
1. Check for damaged cables.
 2. Check for shorted cables.
 3. Check probe sensor setting.

ERROR MESSAGE

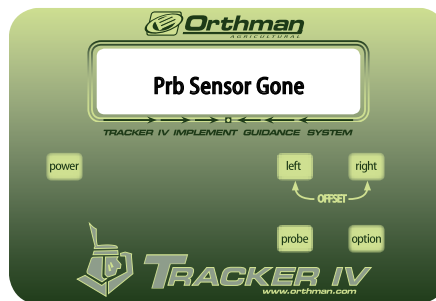

PROBLEM and HELP

PROBLEM:
The Probe Sensor is not being received by the console.

- HELP SUGGESTIONS:**
1. Check the cable connection at the hitch.
 2. Check the cable connection at the probe box.
 3. Check for damaged cables.
 4. Check the cable connection at the probe sensor.
 5. Check the probe sensor setting.



TROUBLESHOOTING

SYSTEM STATUS ERROR CODES



ERROR MESSAGE

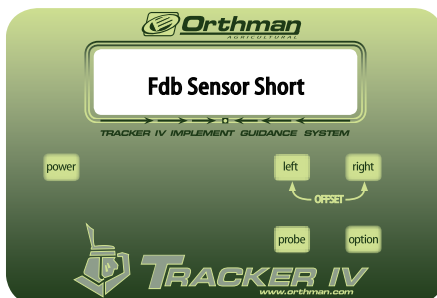

PROBLEM and HELP

PROBLEM:

The Feedback Sensor signal is shorted to ground.

HELP SUGGESTIONS:

1. Check for damaged cables.
2. Check for shorted cable.
3. Check Feedback Sensor setting.

ERROR MESSAGE

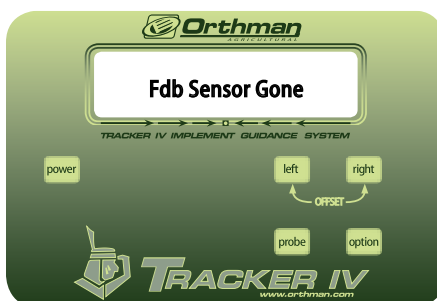

PROBLEM and HELP

PROBLEM:

The Feedback Sensor signal is not being received by the console.

HELP SUGGESTIONS:

1. Check the cable connector from the Feedback Sensor on the Tracker frame.
2. Check for damaged cables.
3. Check Feedback Sensor setting.

ERROR MESSAGE

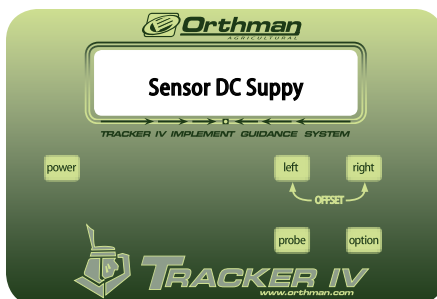

PROBLEM and HELP

PROBLEM:

The sensor supply voltage is shorted to ground.

HELP SUGGESTIONS:

1. Check for damaged cables.
2. Check for shorted connectors.

ERROR MESSAGE

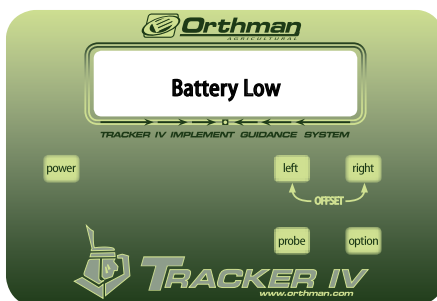

PROBLEM and HELP

PROBLEM:

The supply voltage from the battery is less than 11 volts.

HELP SUGGESTIONS:

1. Check the electrical supply cable.
2. Check the tractor system voltage.



TROUBLESHOOTING

SYSTEM STATUS ERROR CODES



ERROR MESSAGE

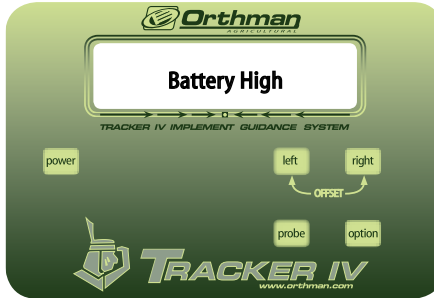

PROBLEM and HELP

PROBLEM:
The console supply voltage is greater than 15 volts. **CONSOLE DAMAGE MAY RESULT IF NOT CORRECTED!**

HELP SUGGESTIONS:
1. Check tractor system voltage.
TURN THE CONSOLE FOO TO PREVENT DAMAGE UNTIL PROBLEM CORRECTED!

ERROR MESSAGE

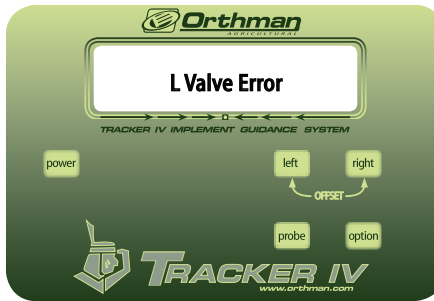

PROBLEM and HELP

PROBLEM:
The Left Steering Valve is either disconnected or overloading.

HELP SUGGESTIONS:
1. Check the cable connector out of the hydraulic manifold.
2. Check for damaged cables.

ERROR MESSAGE

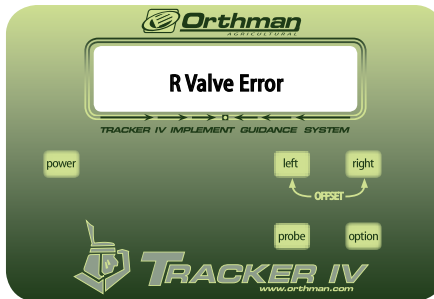

PROBLEM and HELP

PROBLEM:
The Right Steering Valve is either disconnected or overloading.

HELP SUGGESTIONS:
1. Check the cable connector out of the hydraulic manifold.
2. Check for damaged cables.

ERROR MESSAGE

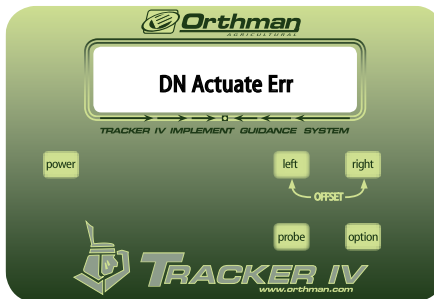

PROBLEM and HELP

PROBLEM:
The Probe Actuator Down Relay is either disconnected or overloading.

HELP SUGGESTIONS:
1. Check all probe box cables.
2. Check all probe box cable connections.
3. Check all cables for damage.



TROUBLESHOOTING

SYSTEM STATUS ERROR CODES



ERROR MESSAGE

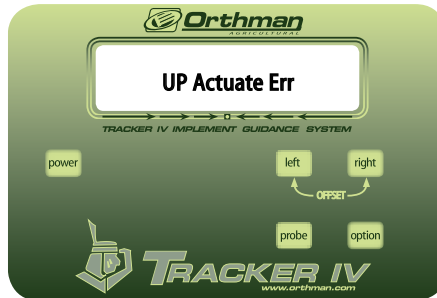

PROBLEM and HELP

PROBLEM:

The Probe Actuator Up Relay is either disconnected or overloading.

HELP SUGGESTIONS:

1. Check all probe box cables.
2. Check all probe box cable connections.
3. Check all cables for damage.

ERROR MESSAGE

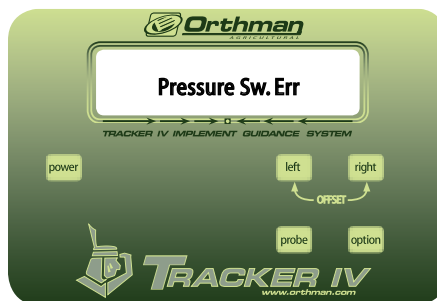

PROBLEM and HELP

PROBLEM:

The switch in the Tracker hydraulic system is not signaling the controller that hydraulic pressure is being supplied to the proper hose.

HELP SUGGESTIONS:

1. Check hydraulic coupler connections.
2. Check to make sure proper hose is pressurized.
3. Check to make sure proper tractor hydraulic control lever is fully engaged.
4. Check for damaged cables and connectors.

ERROR MESSAGE

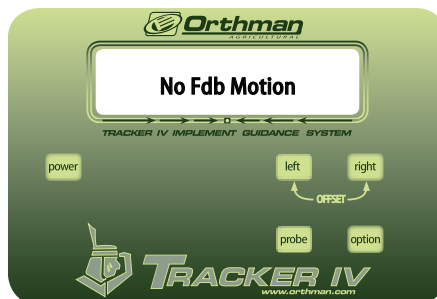

PROBLEM and HELP

PROBLEM:

The Feedback/steering is not responding to control commands.

HELP SUGGESTIONS:

1. Check that the proper hose is pressurized.
2. Check that the proper tractor hydraulic control lever is fully engaged.
3. Check for damaged cables and connectors.



TROUBLESHOOTING

FIELD SERVICE DIAGNOSTIC MODES



The console buttons are used to access all diagnostic modes. The console has four buttons which are used to access all of the functions illustrated below and on the following pages. If adjustments are required for optimum performance, the default settings can be altered by using either the PROBE button or the LEFT or RIGHT OFFSET buttons. See the instructions below for operation instructions. The field service diagnostic modes are accessed by holding down both the LEFT and RIGHT OFFSET buttons on the console and turning ON the console with the POWER button. Press the OPTION button to sequentially scroll through the following diagnostic modes.

LCD DISPLAY



DIAGNOSTIC MODE - INSTRUCTIONS

MANUAL STEER:

Steer Left-Right allows the Tracker to be steered by pressing the LEFT or RIGHT button on the console. The display should be centered and travel right when the RIGHT button is pushed and vice versa. If not centered proceed to scroll to Feedback Calibration diagnostic mode.

LCD DISPLAY

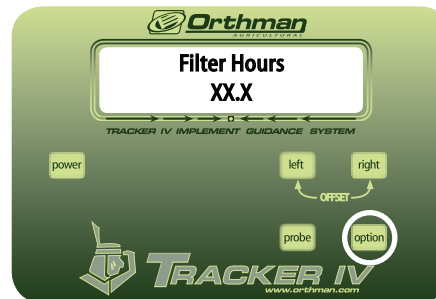

DIAGNOSTIC MODE - INSTRUCTIONS

MONITOR FILTER HOURS:

Hydraulic Filter Hours displays the elapsed hours of field operation since the last filter reset. The filter should be cleaned or replaced every 100 hours of operation. Press the OPTION button.

Reset filter hours instruction directly below.

LCD DISPLAY

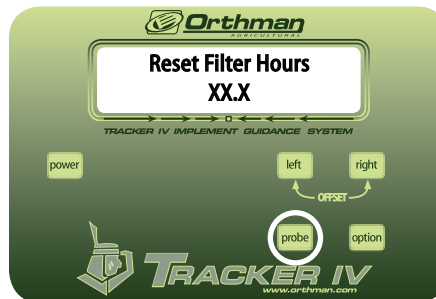

DIAGNOSTIC MODE - INSTRUCTIONS

RESET FILTER HOURS:

Reset filter hours displays the filter hours as outlined above. If the filter has been cleaned or replaced, reset the hours to zero. Hold down the PROBE button for approximately 10 seconds until the alarm sounds and "New Data Saved" is displayed on the screen. Press the OPTION button.



TROUBLESHOOTING

FIELD SERVICE DIAGNOSTIC MODES



LCD DISPLAY

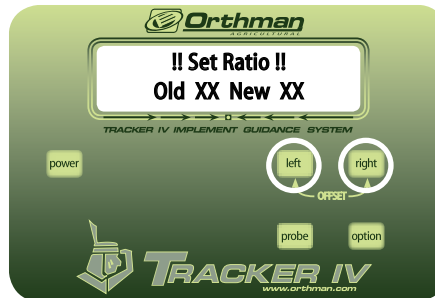

DIAGNOSTIC MODE - INSTRUCTIONS

RATIO:

Set ratio controls the magnitude of blade movement to probe movement. In the default setting of 10 with a range from 1 to 10, the blades will move fully when the probe is at its extreme. For straight rows during planting and bedding operations, turn down the ratio. For cultivating, increase the ratio. Press the LEFT OFFSET to decrease and RIGHT OFFSET to increase ratio. Save the new value by pressing the OPTION button.

LCD DISPLAY

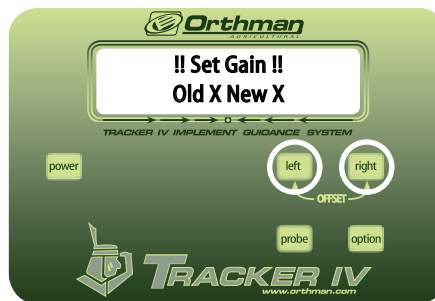

DIAGNOSTIC MODE - INSTRUCTIONS

GAIN:

Set Gain controls the reaction speed of the Tracker. The default setting is 5 with a range from 0 to 10. Lower the setting with the LEFT OFFSET button to dampen the reaction during bedding and planting operations. Increase the setting with the RIGHT OFFSET button for a cultivation operation. Save the new settings with the OPTION button.

LCD DISPLAY

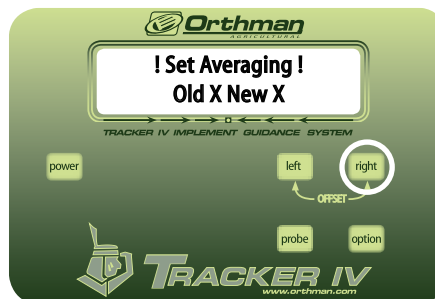

DIAGNOSTIC MODE - INSTRUCTIONS

AVERAGING:

Set averaging reduced the effect of clods and poor sensing conditions of the probe to the movement of the blades. The default setting is 0 or off. The range can be adjusted between 0 and 10. To increase the setting use the RIGHT OFFSET button to improve the stability during bedding and planting. Save the new setting with the OPTION button.

LCD DISPLAY

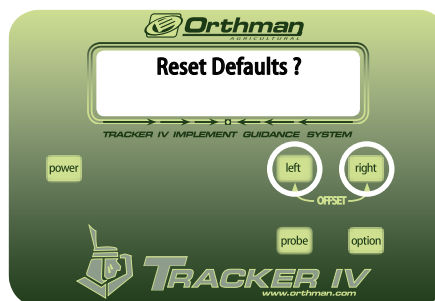

DIAGNOSTIC MODE - INSTRUCTIONS

RESET DEFAULTS:

Reset Defaults is used to reset all settings to default factory settings. Hold down the LEFT and RIGHT OFFSET buttons simultaneously for 15 seconds or until the alarm sounds.

"Reset First Time" will be displayed. Press the OPTION buttons to restore the default settings.



TROUBLESHOOTING

FIELD SERVICE DIAGNOSTIC MODES



LCD DISPLAY

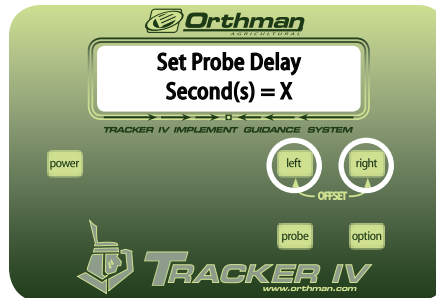

DIAGNOSTIC MODE - INSTRUCTIONS

PROBE DELAY:

Set probe delay adjusts the time between the probe lift switch signal and the Tracker response activation. This delay is shown on the LCD as "Stand By" in field use. The time delay can be adjusted from 0 to 10 seconds by using the LEFT and RIGHT OFFSET buttons. Press the OPTION button to save the new setting.

LCD DISPLAY

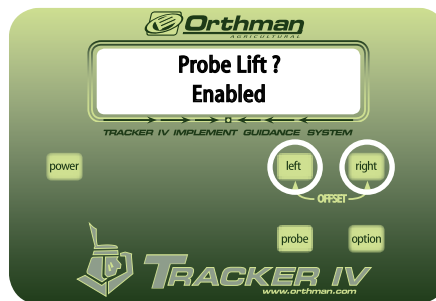

DIAGNOSTIC MODE - INSTRUCTIONS

PROBE LIFT:

Probe Lift allows the operator to enable or disable the lift circuit. When a probe box is utilized, use the enabled setting. Select the enabled setting using the RIGHT OFFSET and disable with the LEFT OFFSET button. Press the OPTION button to save the new setting.

LCD DISPLAY

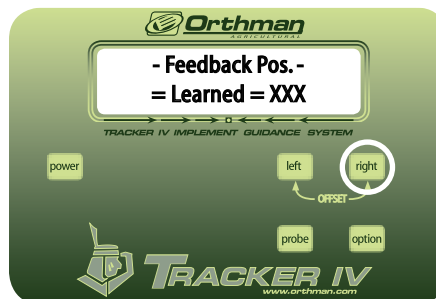

DIAGNOSTIC MODE - INSTRUCTIONS

FEEDBACK POSITION:

Feedback position = Learned monitors the position of the feedback sensor. The range of the setting is -100 to +100 with 0 being the center. Use the LEFT and RIGHT OFFSET buttons to adjust the setting. Press the OPTION button to save the setting.

LCD DISPLAY

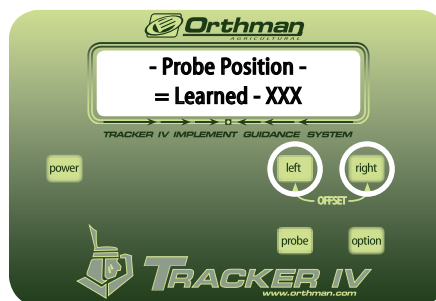

DIAGNOSTIC MODE - INSTRUCTIONS

PROBE POSITION:

Probe position = Learned monitors the position of the probe sensor. The range is from -100 to +100 with 0 being the center. Use the LEFT and RIGHT OFFSET buttons to adjust the setting. Press the OPTION button to save the setting.



TROUBLESHOOTING

FIELD SERVICE DIAGNOSTIC MODES



LCD DISPLAY

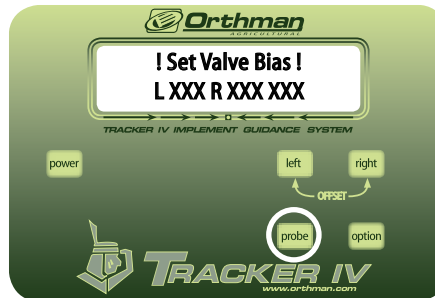

DIAGNOSTIC MODE - INSTRUCTIONS

VALVE BIAS:

Set valve bias is an automatic adjustment used to match the proportional valves with the console software. Voltage is applied to the left and then the right valve to determine at what level each valve opens. Push the PROBE button to begin this mode. The console will automatically perform the necessary testing. The LCD will display the left and right signal from 0 to 195.

NOTE: If the left and right valve read 154 and 154, this is the default setting and the valve needs to be re-calibrated. Push the PROBE button to start automatic calibration adjustment.

Also on the screen, the feedback sensor position will be displayed between -100 and +100. Press the OPTION button to save the new setting.

LCD DISPLAY

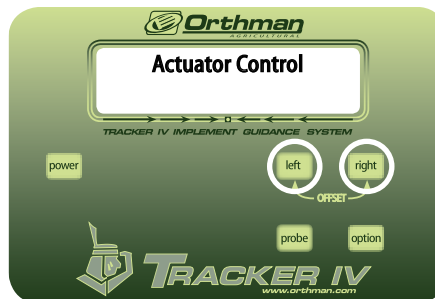

DIAGNOSTIC MODE - INSTRUCTIONS

ACTUATOR CONTROL:

Actuator control is only available in the Probe Lift setting is enabled. If so, raise or lower the probe with the use of the LEFT and RIGHT OFFSET buttons. Press the OPTION button to save the new setting.

LCD DISPLAY

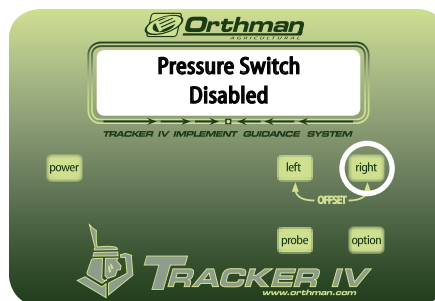

DIAGNOSTIC MODE - INSTRUCTIONS

PRESSURE CONTROL:

Pressure switch is enabled using the RIGHT OFFSET button. It will show the current input from the pressure switch on the hydraulic manifold. If there is at least 100 PSI, the LCD will display "closed". If there is less than 100 PSI the LCD will display "open". If your particular system is not equipped with a pressure switch, leave this setting disabled. Press the OPTION button to save the new setting.



TROUBLESHOOTING

FIELD SERVICE DIAGNOSTIC MODES



LCD DISPLAY

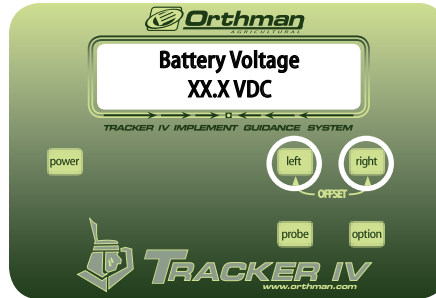

DIAGNOSTIC MODE - INSTRUCTIONS

SUPPLY VOLTAGE:

Battery Voltage will monitor the supply voltage to the console. Proper supply voltage should be in the 13.5 to 14 volt range. To verify proper voltage during operation, monitor voltage while steering the blades using the LEFT or RIGHT OFFSET buttons and raise and lower the probe with the PROBE button. Press the OPTION button to save the setting.

LCD DISPLAY

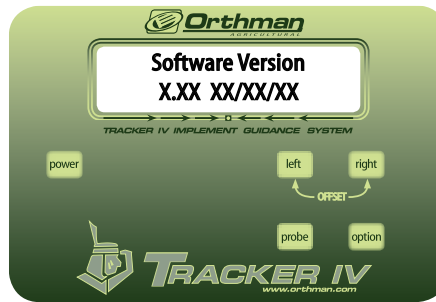

DIAGNOSTIC MODE - INSTRUCTIONS

SOFTWARE VERSION:

Software version displays the version number of the software in the console followed by the month, date, and year when the software was loaded. When new software is installed, this information will automatically update. Press the OPTION button.

LCD DISPLAY

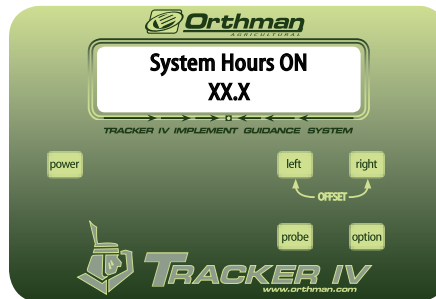

DIAGNOSTIC MODE - INSTRUCTIONS

HOURS ON:

System hours ON shows the total hours the system console has been turned on. Press the OPTION button.

LCD DISPLAY

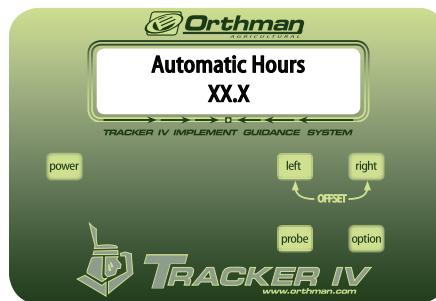

DIAGNOSTIC MODE - INSTRUCTIONS

HOURS IN AUTOMATIC:

Automatic hours shows the total hours the system has been in the active field mode. Press the OPTION button.



TROUBLESHOOTING

FIELD SERVICE DIAGNOSTIC MODES



LCD DISPLAY

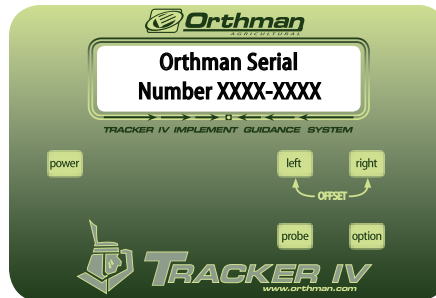

DIAGNOSTIC MODE - INSTRUCTIONS

SERIAL NUMBER:

Orthman serial number shows the serial number under which the console was tested. This number must match the serial tag on the Tracker. The serial number is designated by week, year, and item manufactured that week. Press the OPTION button.

LCD DISPLAY

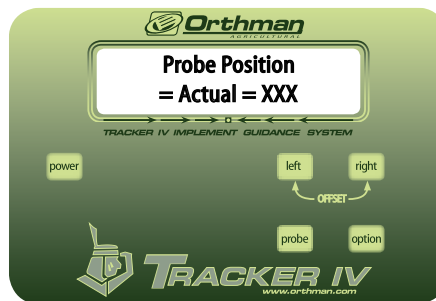

DIAGNOSTIC MODE - INSTRUCTIONS

ACTUAL PROBE POSITION:

Probe Position = Actual is used to readjust or replace the probe sensor in conjunction with the following Probe Calibrate. The probe assembly must be mechanically centered before adjusting the electronics to match the mechanical assembly. An audible as well as number display indicate the position of the sensor.

The number will range from -100 to +100 with 0 being center. The audible beeping will quicken as the sensor is adjusted closer to center and when beeping is steady, the sensor is adjusted close enough for the following Probe Calibrate diagnostic mode to learn the sensor in the exact center. Lock the probe sensor into this centered position.

Press OPTION to proceed to Probe Calibration diagnostic mode.



TROUBLESHOOTING

FIELD SERVICE DIAGNOSTIC MODES



LCD DISPLAY

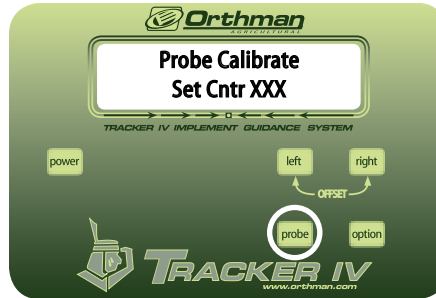

DIAGNOSTIC MODE - INSTRUCTIONS

PROBE CALIBRATE:

Probe calibrate allows the software to fine tune the probe sensor setting. The value displayed will range from -100 to +100 with 0 being center.

To calibrate: first mechanically center the probe assembly and hold centered while the PROBE button is pressed to enter this position as exact center. The numeric must be between -5 and +5. The system will automatically advance to the left extreme. Push the probe assembly to the left extreme and hole while the PROBE button is pressed.

If you have pushed the probe assembly to the wrong side, "Out of Range" will be displayed. If this is to occur, move the assembly to the opposite side and push the PROBE button. The controller will automatically advance to the right extreme. Move the probe assembly to the right extreme and hold while the PROBE button is pressed. Press the OPTION button to store the calibrated center.

LCD DISPLAY

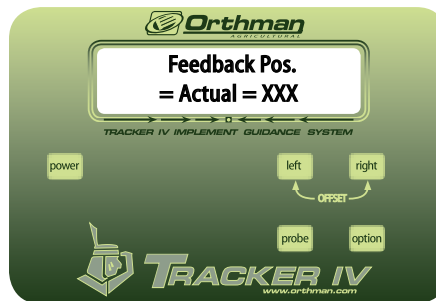

DIAGNOSTIC MODE - INSTRUCTIONS

ACTUAL FEEDBACK POSITION:

Feedback Position = Actual is to be used to re-adjust or replace the feedback sensor in conjunction with the following diagnostic mode: Feedback Calibrate. An audible as well as number display indicate the position of the sensor.

The number will range from -100 to +100 with 0 being the center. The audible beeping will quicken as the sensor is adjusted closer to center and when the beeping is steady, the sensor is adjusted close enough for the following Feedback Calibrate diagnostic mode to learn the sensor in the exact center.

Press the OPTION button to proceed to the Feedback Calibrate diagnostic mode.



TROUBLESHOOTING

FIELD SERVICE DIAGNOSTIC MODES



LCD DISPLAY

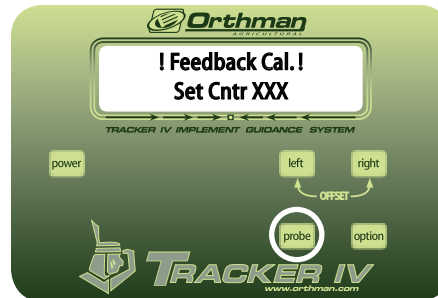

DIAGNOSTIC MODE - INSTRUCTIONS

FEEDBACK CALIBRATE:

Feedback calibrate allows the software to fine tune the feedback sensor settings through software. The value displayed will range from -100 to +100 with 0 being the center. Push the PROBE button to store this sensor position into memory as the exact learned center.

The numeric value must be between -5 to +5 to store this value. The console will automatically advance to the left extreme setting after successfully entering the center value.

Power the Tracker hydraulically and push the LEFT OFFSET button to steer the blades to the left extreme. Push the PROBE button to enter this position as the left extreme. The controller will automatically advance to the right extreme setting. Push the RIGHT OFFSET button to steer the blades to the right extreme. Push the PROBE button to enter this value as the right extreme.



PARTS IDENTIFICATION

TRACKER ARM CLAMP FOR 7 X 7 TOOLBAR

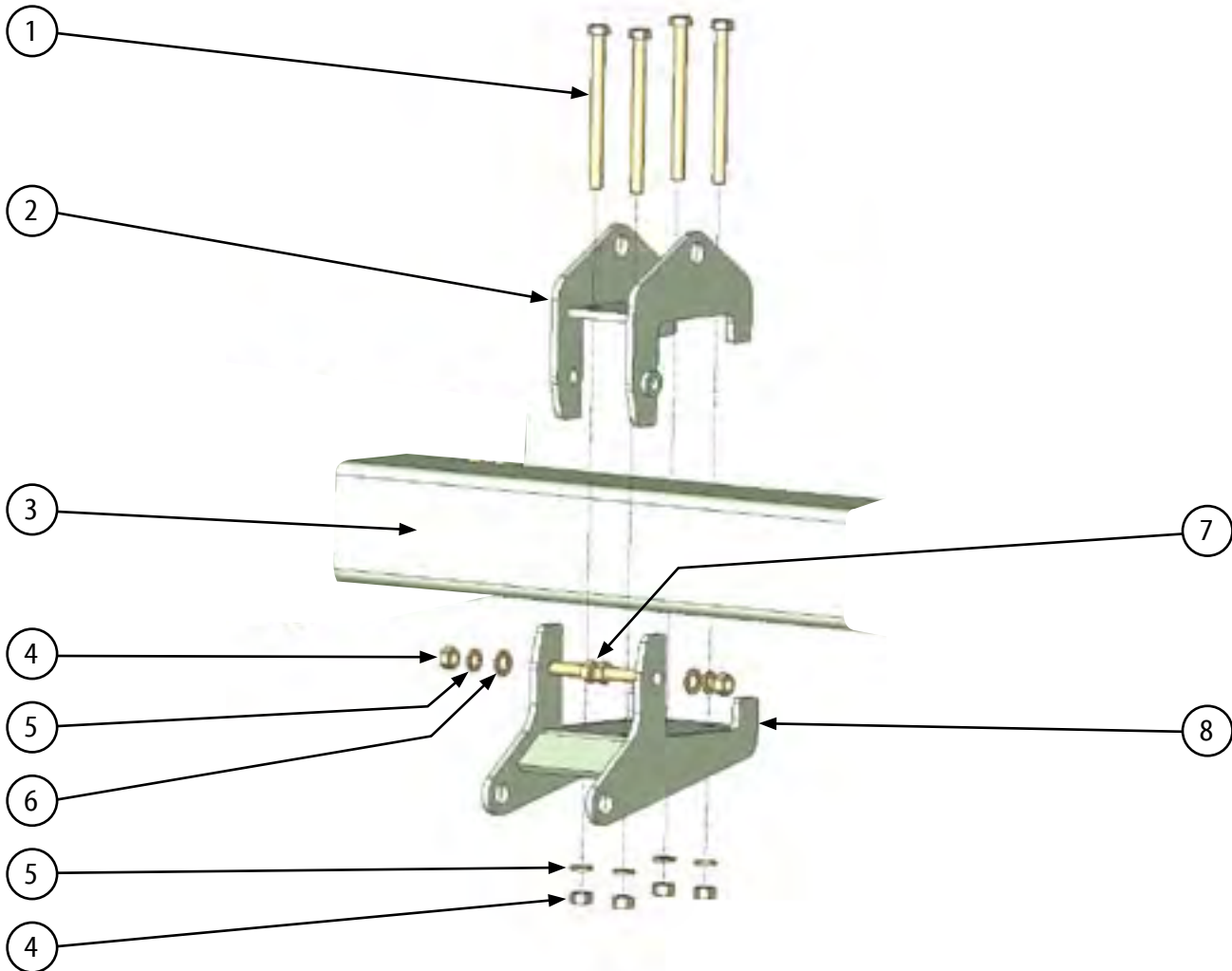

- 1. 100-309 HHCS Bolt • 3/4 - 10 x 9 GR. 8 (4X)
- 2. 333-750 Top Clamp (weld assembly)
- 3. Primary Implement 7 x 7 Toolbar
- 4. 102-009 3/4 Nut (6X)

- 5. 108-022 3/4 Lock Washer (6X)
- 6. 108-003 3/4 Flat Washer (2X)
- 7. 100-075 HHCS Bolt • 3/4 - 10 x 2 1/2 GR. 8 (2X)
- 8. 333-753 Bottom Clamp (weld assembly)



PARTS IDENTIFICATION

TRACKER ARM CLAMP FOR 7 X 7 TOOLBAR AND 5 X 7 HITCH

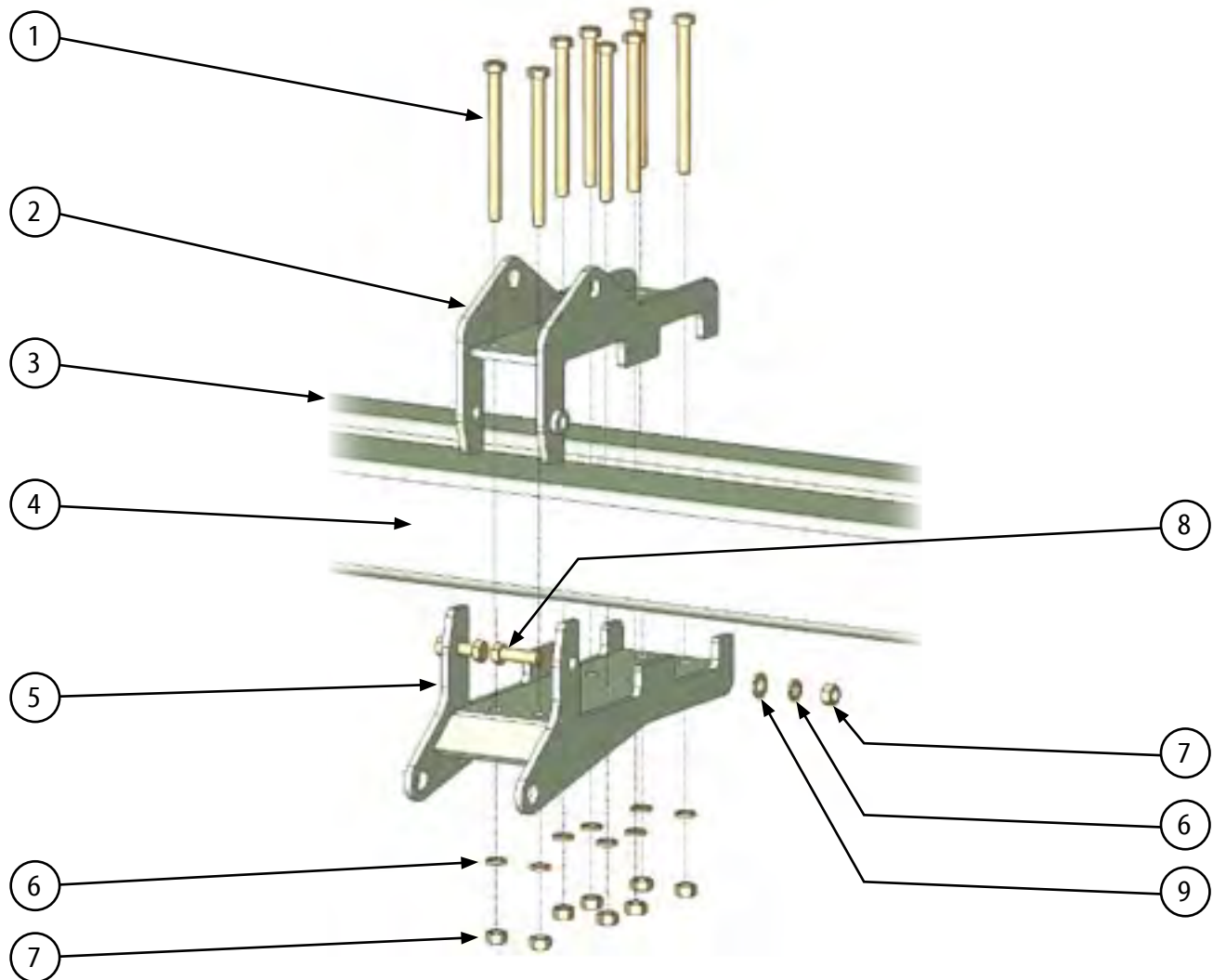

1. 100-309 HHCS Bolt • 3/4 - 10 x 9 GR. 8 (8X)
2. 333-757 Top Clamp (weld assembly)
3. Orthman 5 x 7 Hitch
4. Primary Implement 7 x 7 Toolbar
5. 333-760 Bottom Clamp (weld assembly)

6. 108-022 3/4 Lock Washer (10X)
7. 102-009 3/4 Nut (10X)
8. 100-075 HHCS Bolt • 3/4 - 10 x 2 1/2 GR. 8 (2X)
9. 108-003 3/4 Flat Washer (2X)



PARTS IDENTIFICATION

STANDARD TURNBUCKLE

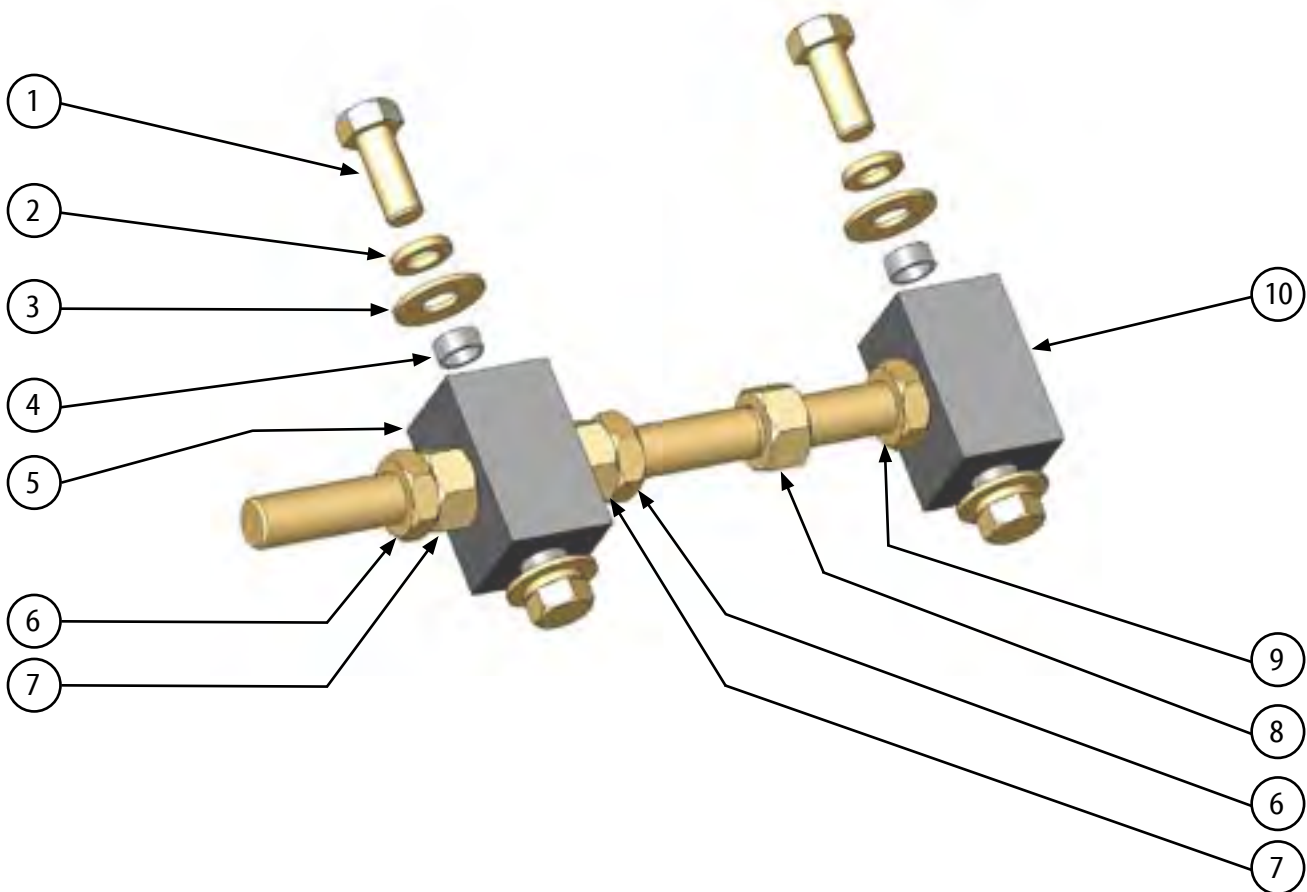

- 1. 100-246 HHCS Bolt • 1 - 8 x 2 1/2 GR, 5 (4X)
- 2. 108-025 1" Lock Washer (4X)
- 3. 108-014 1" Flat Washer (4X)
- 4. 302-658 Bushing Adj. Dual Bar SP.9/16 (4X)
- 5. 401-014 Trunion Test Fixture 3" Sq.
(green - RH threaded)

- 6. 102-063 1 3/8 RH Thread Jam Nut GR. 2 (2X)
- 7. 102-040 1 3/8 - 6 Plated Hex Nut GR. 2 (2X)
- 8. 401-012 Turnbuckle Weld Assembly
- 9. 102-064 1 3/8 LH Thread Jam Nut GR. 2
- 10. 401-015 Trunion Test Fixture 3" Sq.
(black - LH threaded)



PARTS IDENTIFICATION

CUSHION TURNBUCKLE

NOTE: The Cushion Turnbuckle is standard equipment on all Trackers utilized on 1800 and 1900 Orthman Toolbars. The Cushion Turnbuckle is optional equipment on all other Trackers.

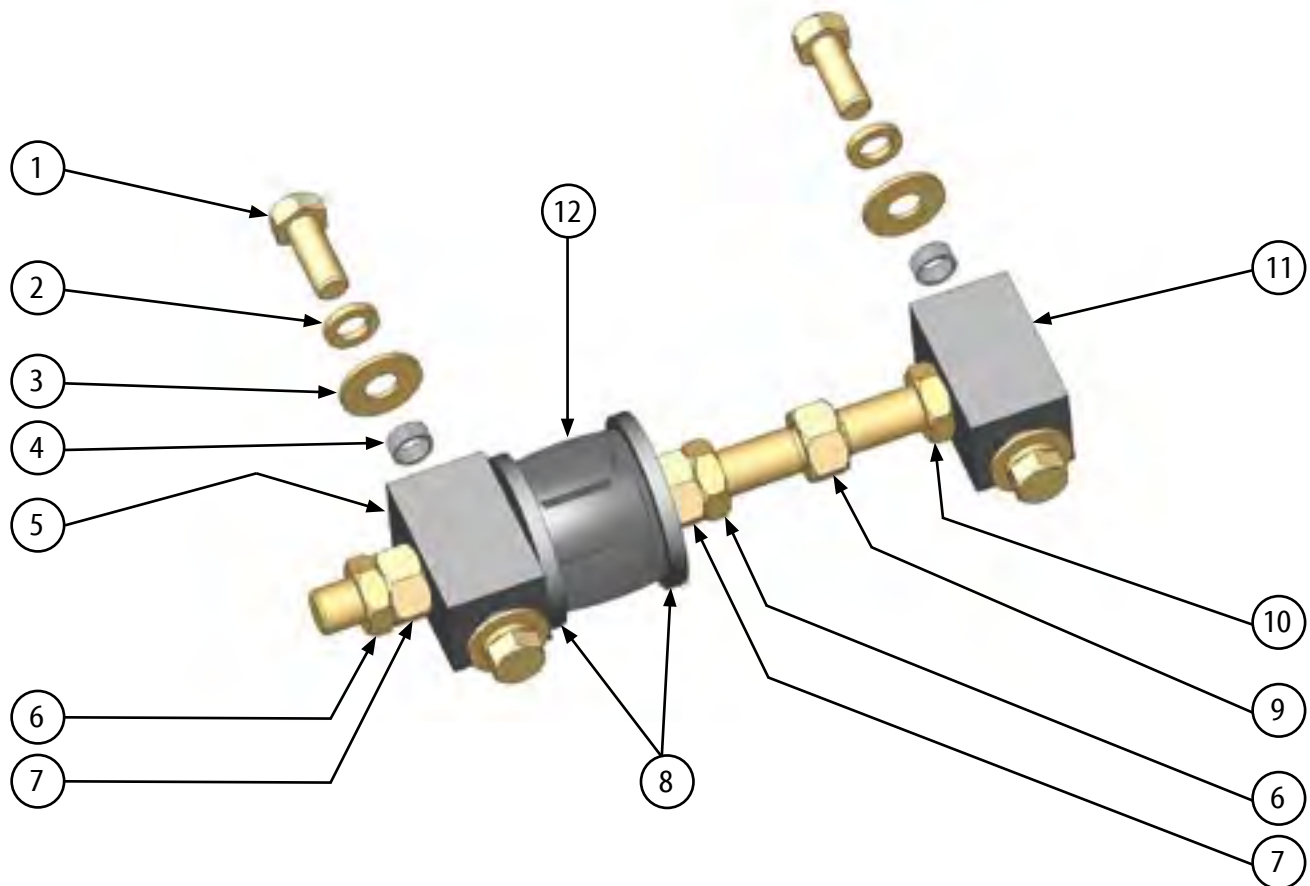

1. 100-246 HHCS Bolt • 1 - 8 x 2 1/2 GR,5 (4X)
2. 108-025 1" Lock Washer (4X)
3. 108-014 1" Flat Washer (4X)
4. 302-658 Bushing Adj. Dual Bar SP.9/16 (4X)
5. 401-014 Trunion Test Fixture 3" Sq.
(green - RH threaded)
6. 102-063 1 3/8 RH Thread Jam Nut GR.2 (2X)

7. 102-040 1 3/8 - 6 Plated Hex Nut GR.2 (2X)
8. 401-013 Plate Text Fixture Slip (2X)
9. 401-012 Turnbuckle Weld Assembly
10. 102-064 1 3/8 LH Thread Jam Nut GR.2
11. 401-015 Trunion Test Fixture 3" Sq.
(black - LH threaded)
12. 333-309 Urethane Damper Spring



PARTS IDENTIFICATION

ARM ASSEMBLIES

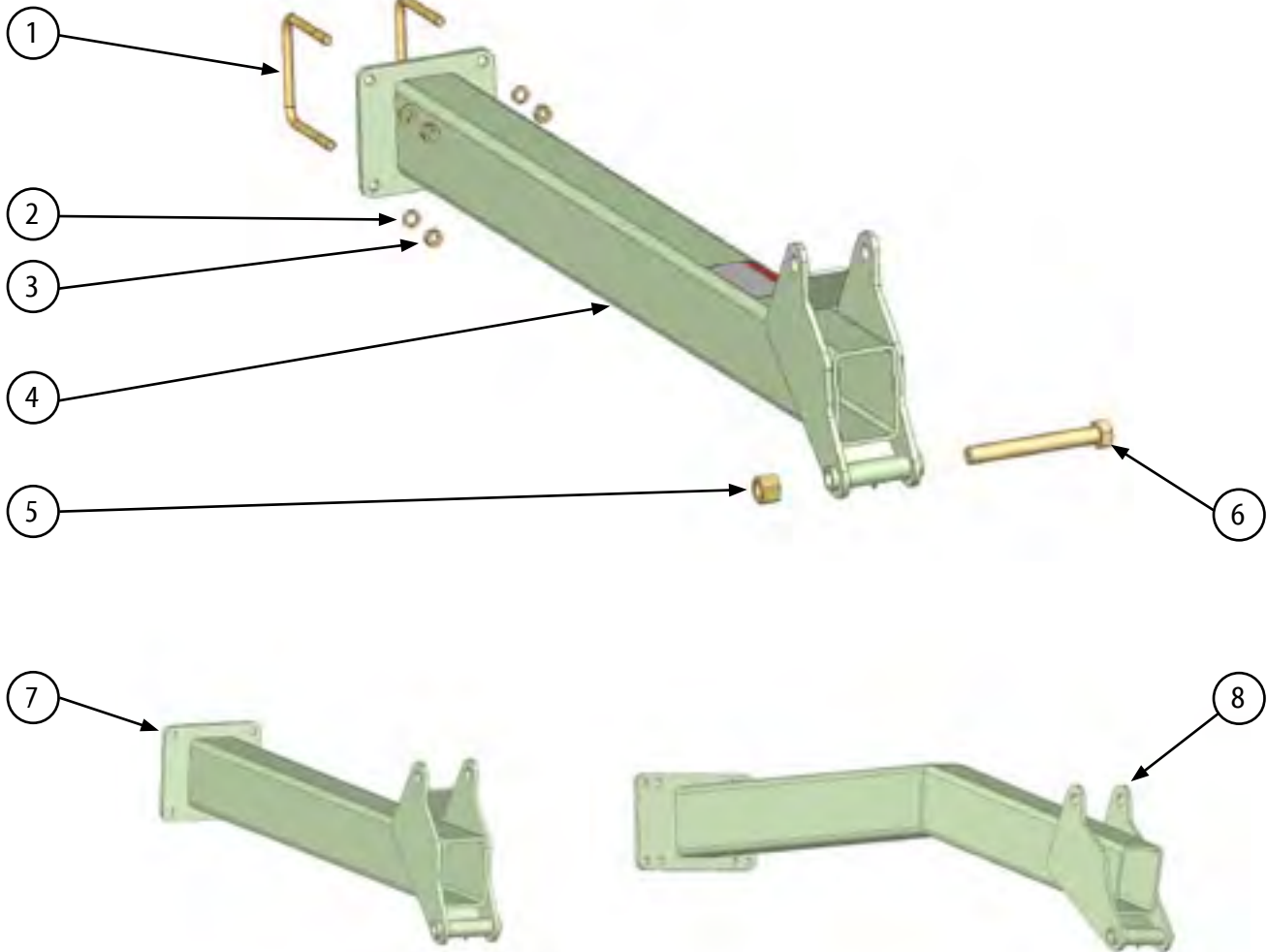

1. 315-028 U-Bolt 3/4 (5x7 Bar) (21 1/4) (2X)
2. 108-022 3/4 Lock Washer(4X)
3. 102-009 3/4 Nut (4X)
4. 333-748 Standard 77" Arm for Cultivator
5. 102-091 Nylock Nut 1 1/4 - 7 GR.2
6. 100-518 HHCS Bolt 1 1/4 - 7 x 10 GR.5 YZ
7. 333-766 58" Arm for 8315 or Lister Unit
8. 333-772 78" Arm for Planter



PARTS IDENTIFICATION

ARM ASSEMBLY - 1800 TOOLBAR

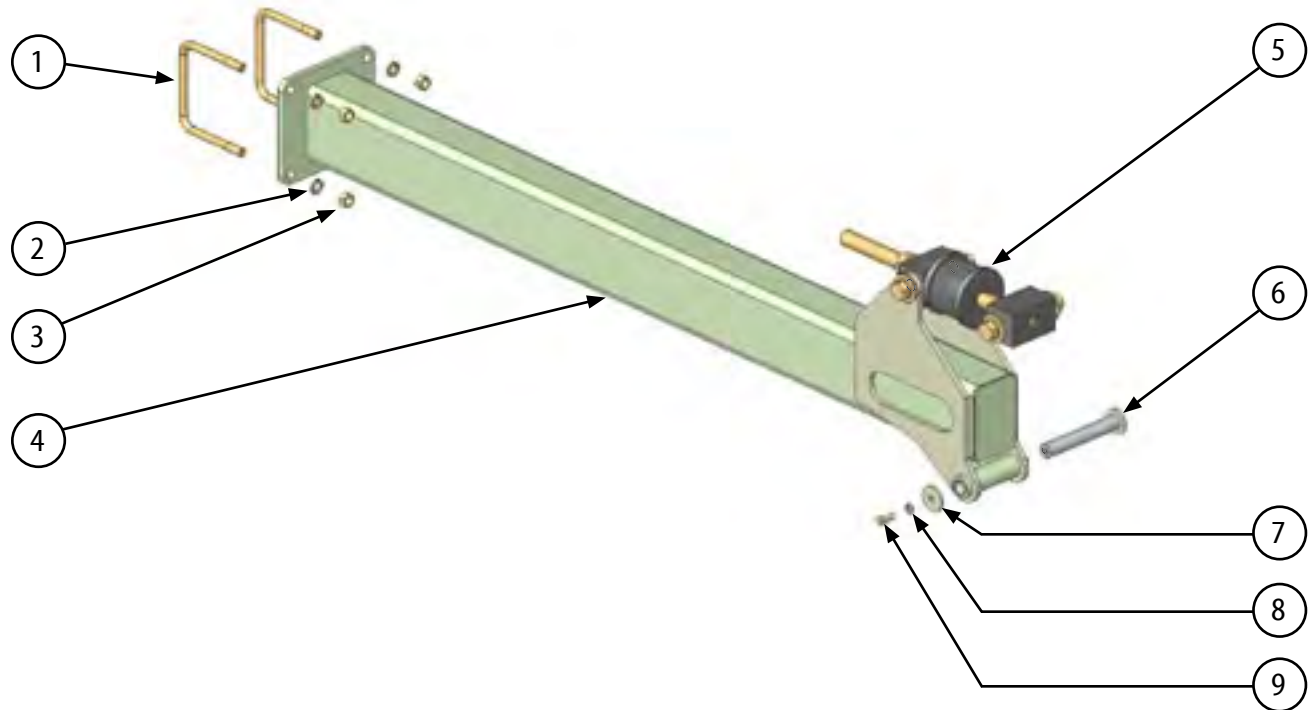

1. 315-028 U-Bolt 3/4 (5x7 Bar) (21 1/4) (2X)
2. 108-022 Lockwasher 3/4 (4X)
3. 102-009 Hex Nut 3/4 - 10 GR. 5 (4X)
4. 333-313 79" Arm for 1800 Toolbar
5. 333-318 Cushion Turnbuckle Package
6. 333-776 Pin Weld Assembly
7. 333-737 1/2" Washer Pin Head
8. 108-020 Lockwasher 1/2"
9. 100-115 HHCS Bolt 1/2 - 13 x 1 1/4 GR. 5



PARTS IDENTIFICATION

ARM ASSEMBLY - 1900 TOOLBAR

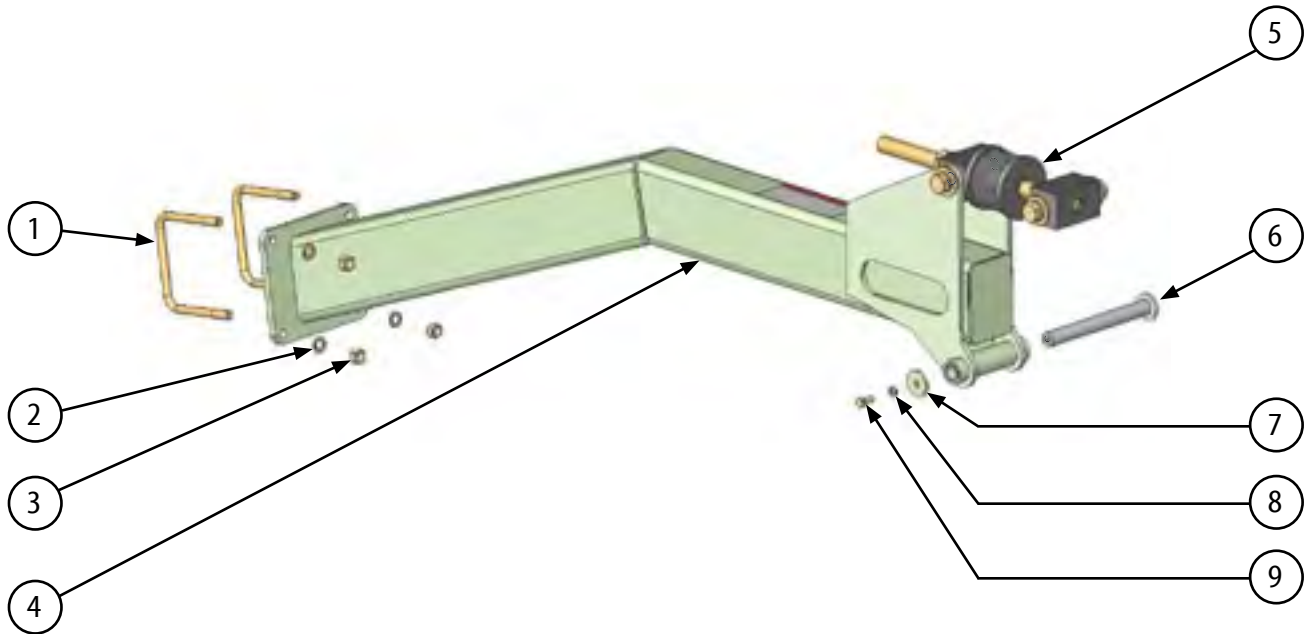

1. 315-028 U-Bolt 3/4 (5x7 Bar) (21 1/4) (2X)
2. 108-022 Lockwasher 3/4 (4X)
3. 102-009 Hex Nut 3/4 - 10 GR. 5 (4X)
4. 333-313 79" Arm for 1800 Toolbar
5. 333-318 Cushion Turnbuckle Package
6. 333-745 Pin Weld Assembly
7. 333-737 1/2" Washer Pin Head
8. 108-020 Lockwasher 1/2"
9. 100-115 HHCS Bolt 1/2 - 13 x 1 1/4 GR. 5



PARTS IDENTIFICATION

BLADE, HUB, and YOKE ASSEMBLY

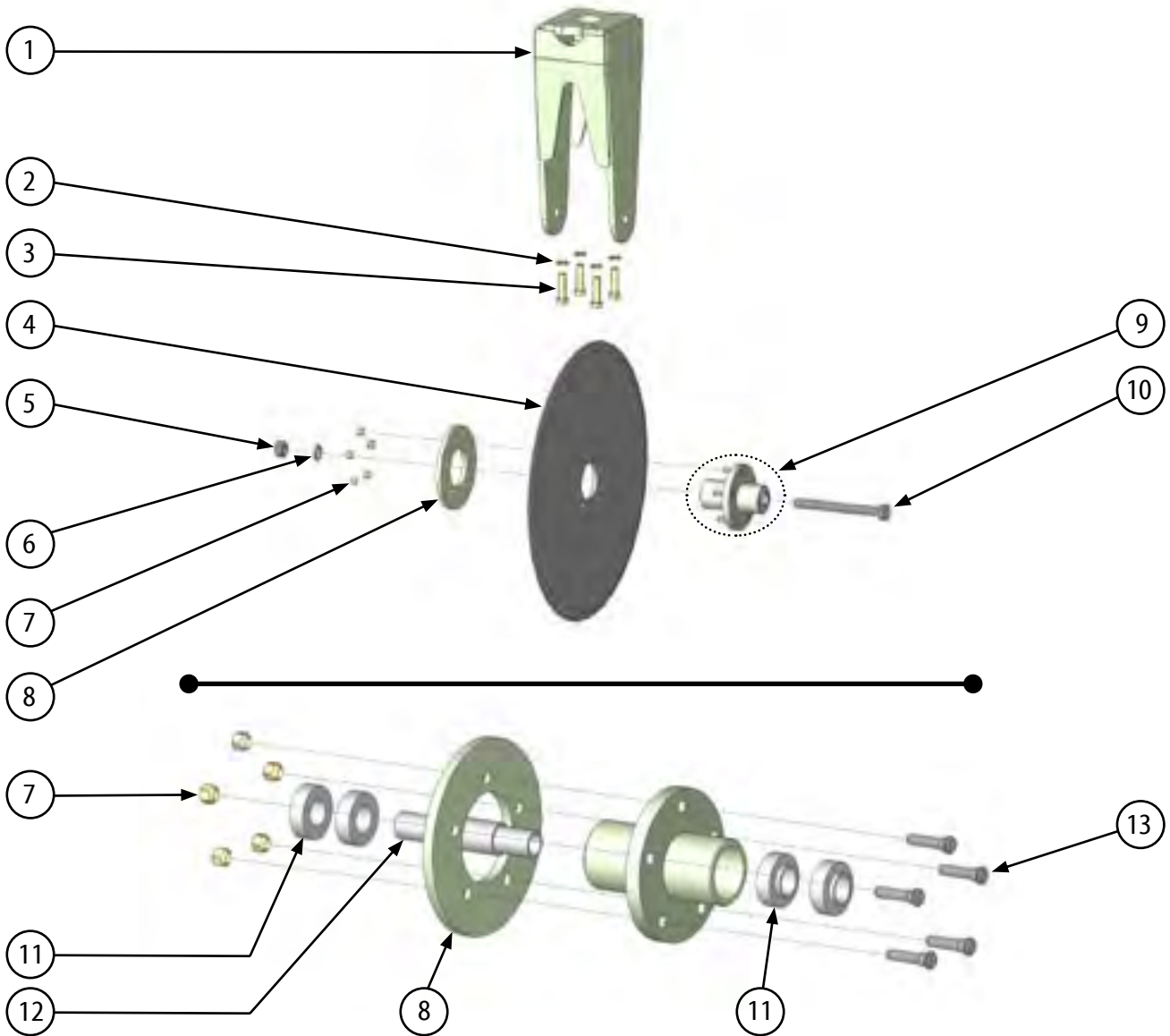

- 1. 333-615 Yoke Tracker weld assembly
- 2. 108-022 Lockwasher 3/4" (2X)
- 3. 100-159 HHCS Bolt 3/4-10 x 2 3/4 GR.5 (4X)
- 4. 166-047 Tracker Blade
- 5. 102-011 Hex Nut 1"- 8 GR.2
- 6. 108-025 Lockwasher 1"
- 7. 102-039 Nut 1/2 - 20 GR.5 • 45° (5X)

- 8. 333-533 Hub Strengthening Plate
- 9. 331-901 Tracker Blade Double Bearing Hub Assembly
- 10. 100-199 HHCS Bolt 1" - 8 x 10 GR.8
- 11. 120-036 Bearing 1.25 (4X)
- 12. 331-905 Spacer Double Bearing Hub
- 13. 100-335 Stud Bolt 1/2 - 20 x 2 1/8 (5X)



PARTS IDENTIFICATION

SENSOR SPINDLE ASSEMBLY

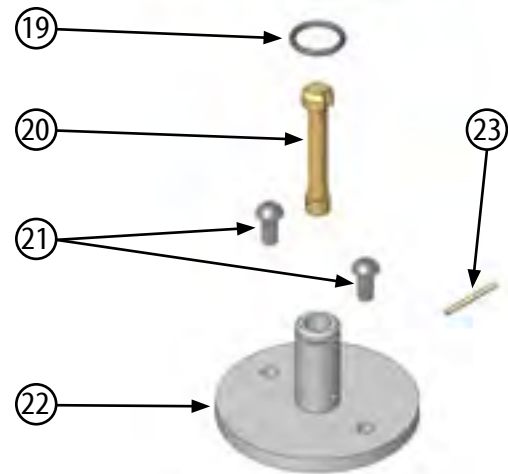
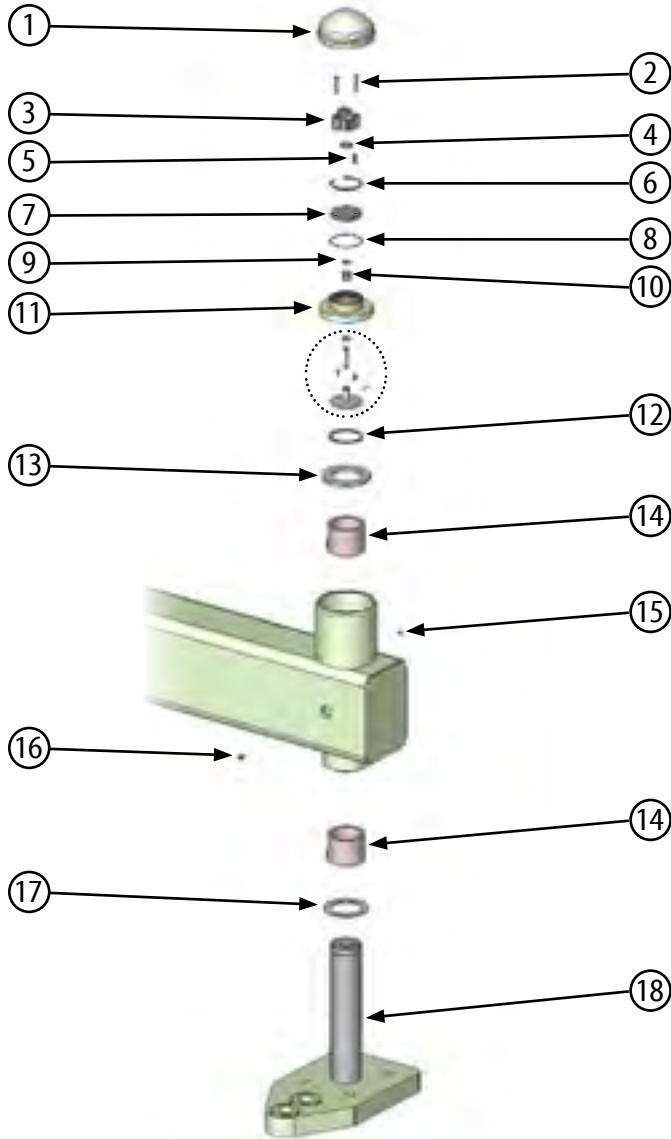

- 1. 333-656 Tracker IV Sensor Cap Assy.
- 2. 106-059 Round Head Machine Screw
8 - 3 x 1 1/4 Slotted Drive (2X)
- 3. 154-649 Sensor 45° Rotary Position
- 4. 150-079 O-Ring #115 SAE 120R1 Class 1
- 5. 106-141 Round Head Machine Screw
6 - 32 x 3/8"
- 6. 104-113 Ring Spiral 2 1/4 Bore
- 7. 350-066 Sensor Mounting Plate

- 8. 150-081 O-Ring #035 SAE 120R1 Class 1
- 9. 104-111 Snap Ring Ext. 1/2
- 10. 134-051 Bearing 1/2 ID x 1/2 Long
- 11. 333-637 Sensor Mount
- 12. 104-197 Snap Ring Ext. 2 1/4 Shaft
- 13. 333-638 Washer - Spindle Top
- 14. 120-134 Bushing 2 1/4 ID x 2 3/4 OD x 2" (2X)
- 15. 106-177 Set Screw 1/4 - 28 x 1/4
- 16. 110-001 Grease Zerk 1/4 - 28
- 17. 134-096 Bushing 2 1/4 x 3 1/4 x .080
- 18. 333-633 Spindle
- 19. 150-082 O-Ring #014 SAE 120R1 Class 1
- 20. 152-413 Sensor Driveshaft
- 21. 106-045 Round Head Machine Screw
8 - 32 x 3/8 (2X)
- 22. 333-641 Sensor Plate
- 23. 104-069 Roll Pin 1-16 x 7/8 Spiral



PARTS IDENTIFICATION

STANDARD SPINDLE ASSEMBLY

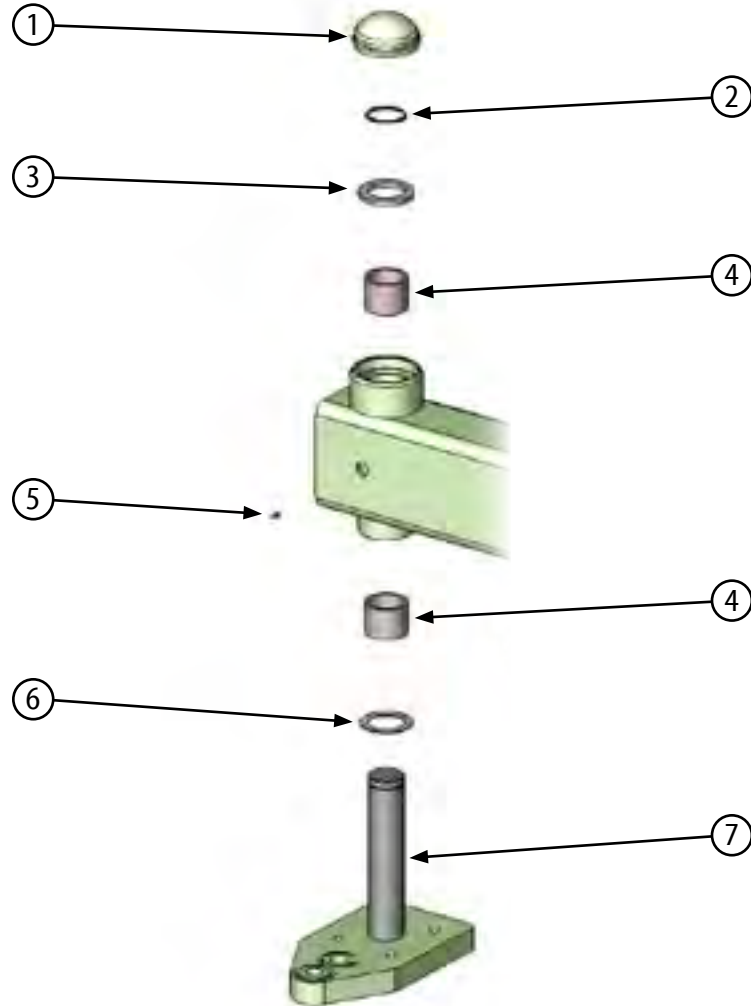

1. 333-655 Standard Spindle Cap
2. 104-197 Snap Ring Ext. 2 1/4 Shaft
3. 333-638 Washer Spindle Top
4. 120-134 Bushing 2 1/4 ID x 2 3/4 OD x 2"
5. 110-001 Grease Zerk 1/4 - 28
6. 134-096 Bushing 2 1/4 x 3 1/4 x .080
7. 333-651 Standard Spindle



PARTS IDENTIFICATION

PROBE BOX ASSEMBLY

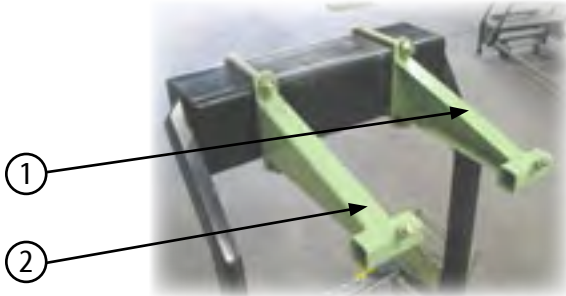

①

②

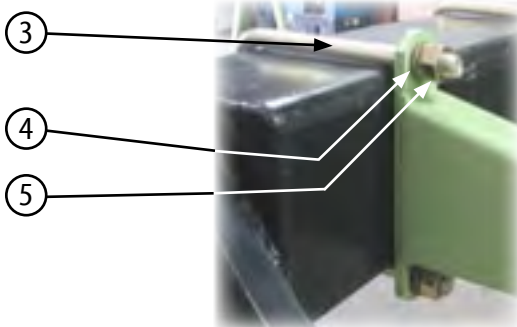

③

④

⑤

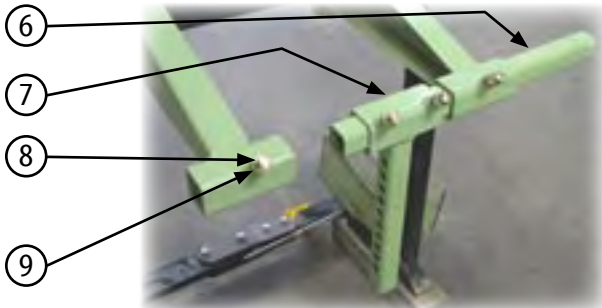

⑥

⑦

⑧

⑨



⑩



⑪

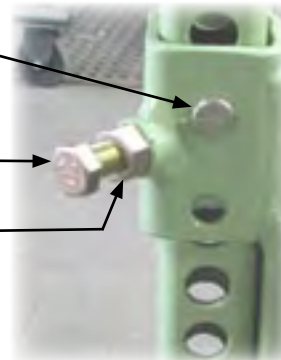

⑫

⑬

⑭

- 1. 315-349 Probe Box Extension LH
- 2. 315-350 Probe Box Extension RH
- 3. 315-031 U-Bolt 3/4" 7 x 7 Bar (2X)
- 4. 102-002 Lock Washer 3/4" (4X)
- 5. 102-009 Hex Nut 3/4" x 10 (4X)
- 6. 315-356 Probe Box Brace
- 7. 315-355 Probe Box Tube
- 8. 106-010 Square Head Set Screw 1/2" - 13 x 1 1/2" (4X)
- 9. 102-015 Jam Nut 1/2" x 13 GR.2 (4X)

- 10. 305-890 Probe Box with Sensor Lift
- 11. 104-073 Hair Pin Cotter Pin .120 x 2 1/2"
- 12. 104-088 Clevis Pin 1/2" x 2 3/4"
- 13. 100-364 HHCS M12 x 40 GR.5
- 14. 102-057 Jam Nut MM12 GR.2



PARTS IDENTIFICATION

FEELER ROD PACKAGE ASSEMBLY

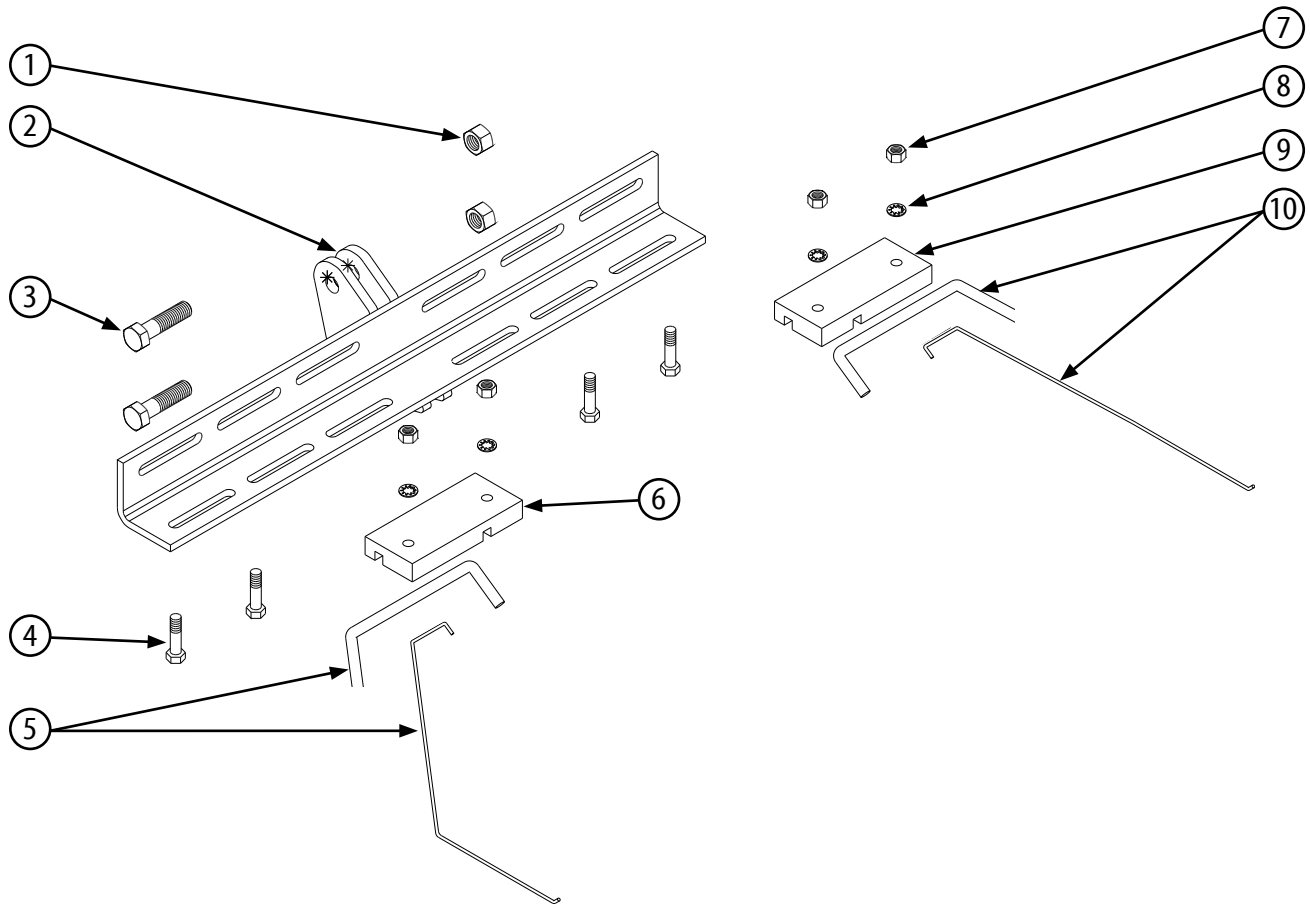

- 1. 102-176 Nut Hex M10 GR.2 (2X)
- 2. 305-800 Lift Tracker Feeler Rod w/a
- 3. 100-357 HHCS Bolt M10 x 35 GR.5 (2X)
- 4. 100-343 HHCS Bolt M6 x 1 x 25 GR.8 (4X)
- 5. 350-798 Feeler Rod LH

- 6. 305-596 Feeler Block LH
- 7. 102-174 Hex Nut M6 GR.5 (4X)
- 8. 108-093 Internal Tooth Lock Washer 6MM (4X)
- 9. 305-595 Feeler Block RH
- 10. 350-797 Feeler Rod RH

(NOTE: #5 and #10 (feeler rods) are notated twice with arrows although there one per RH and LH side of the assembly)



PARTS IDENTIFICATION

DOUBLE IN-LINE PROBE BALL PACKAGE ASSEMBLY

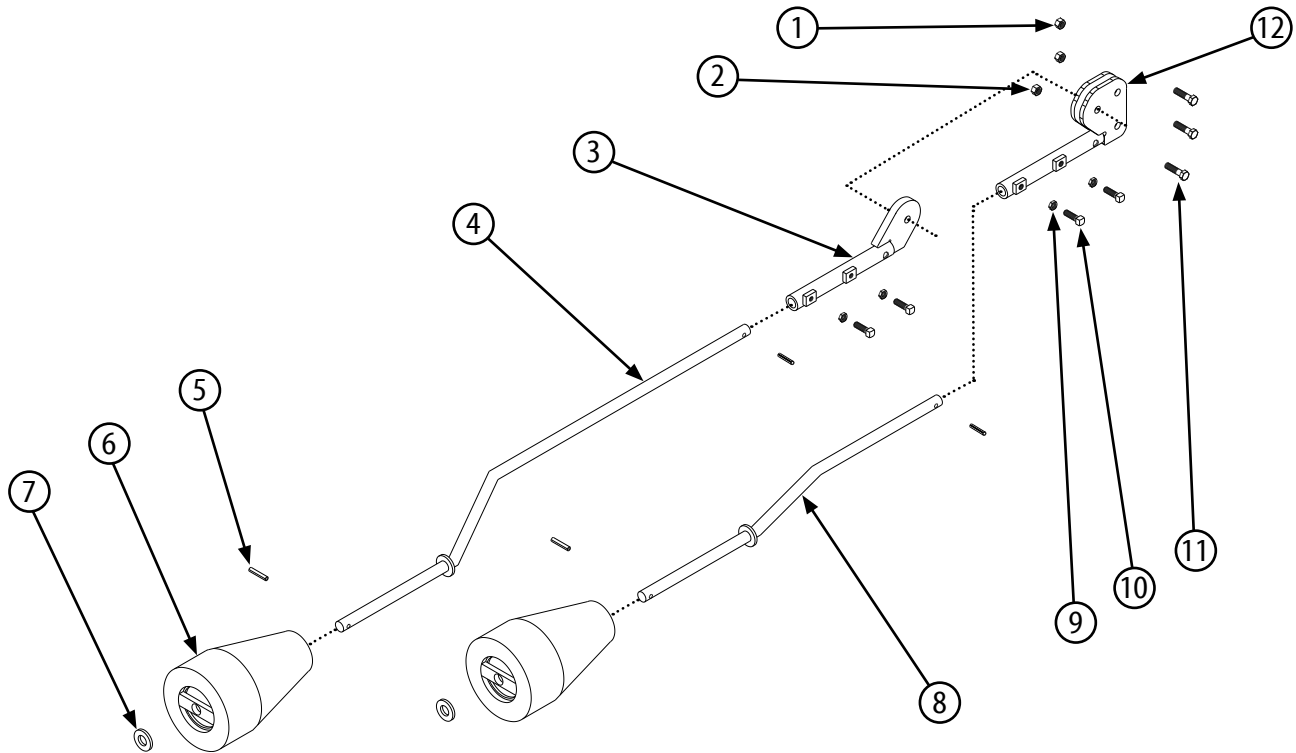

1. 102-176 Nut Acorn 6-32 GR.2 (2X)
2. 102-089 Nut Wheel 3/4-16 SAE GR. 8
3. 305-875 Lift Tracker Upper Probe
4. 330-933 Rod Tracker Long Follower
5. 104-010 Roll Pin 3/16 x 1 (4X)
6. 317-565 Tracker Probe (2X)

7. 108-009 Flat Washer 1/2 (2X)
8. 330-932 Rod Tracker Short Follower
9. 102-057 Jam Nut 5/16 - 18 GR.2 (4X)
10. 106-023 Square Head Screw 5/16 - 18 x 3/4 (4X)
11. 100-353 HHCS Bolt M10 x 40 GR.5 (3X)
12. 305-822 Mount Tracker Lower Probe



PARTS IDENTIFICATION

TRIPLE PROBE BALL PACKAGE ASSEMBLY

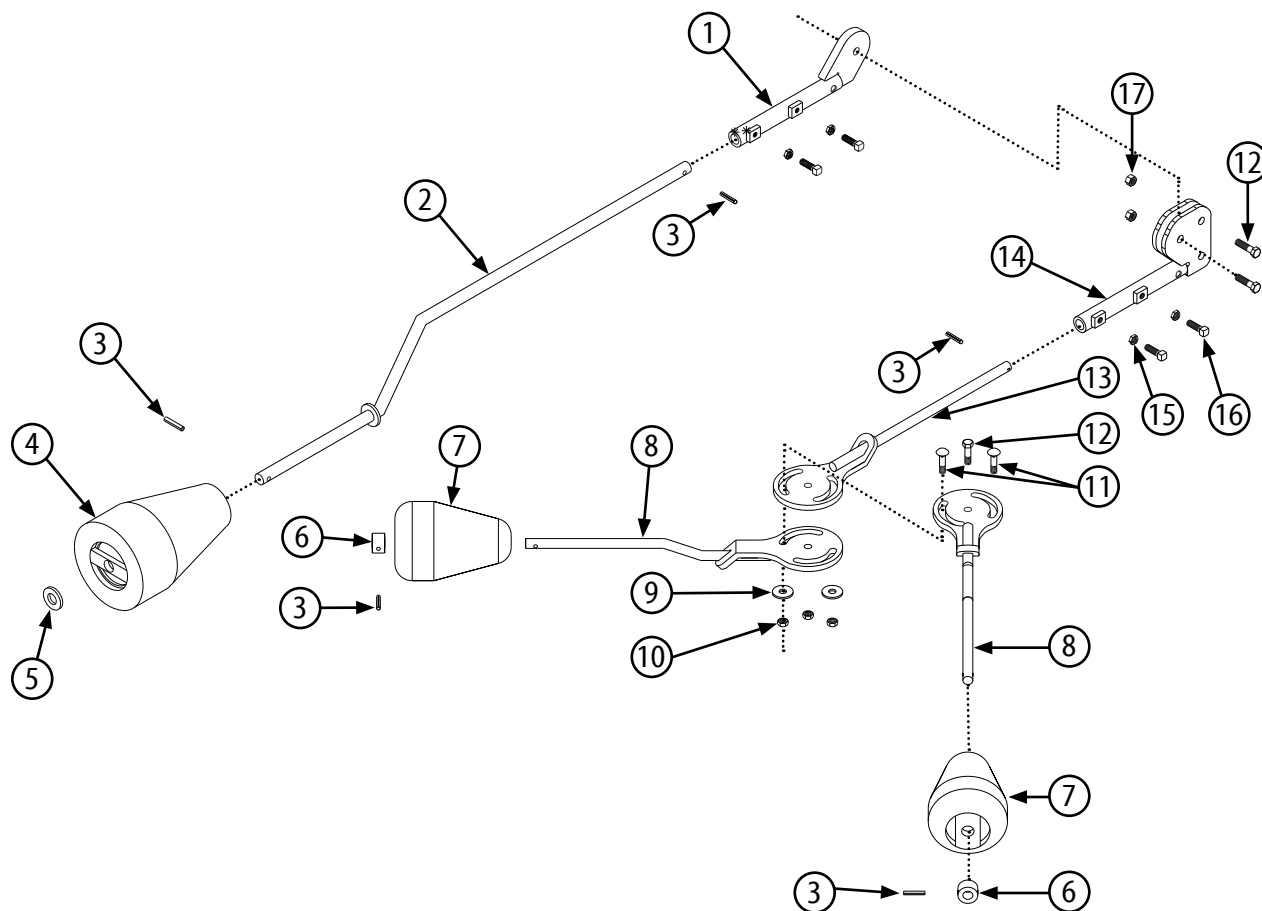

- 1. 305-875 Upper Probe Lift
- 2. 330-933 Long Follower Rod
- 3. 104-010 Roll Pin 3/16 x 1 (5X)
- 4. 317-565 Tracker Probe (3X)
- 5. 108-009 Flat Washer 1/2 (2X)
- 6. 332-628 Probe Ball Stop (2X)

- 7. 317-565 Probe Bulb
- 8. 332-629 Outer Rod (2X)
- 9. 108-101 Flat Washer M10.5 x 21 x 2 (2X)
- 10. 102-189 Lock Nut M10 (3X)
- 11. 100-068 Carriage Bolt M10 x 40 (2X)
- 12. 100-353 Bolt M10 x 40 (3X)

- 13. 332-625 Center Rod
- 14. 305-822 Lower Probe Mount
- 15. 102-057 Jam Nut 5/16 (4X)
- 16. 106-023 Set Screw 5/16 x 3/4 (4X)
- 17. 102-176 Nut M10 (2X)



PARTS IDENTIFICATION

TIE-ROD ASSEMBLIES

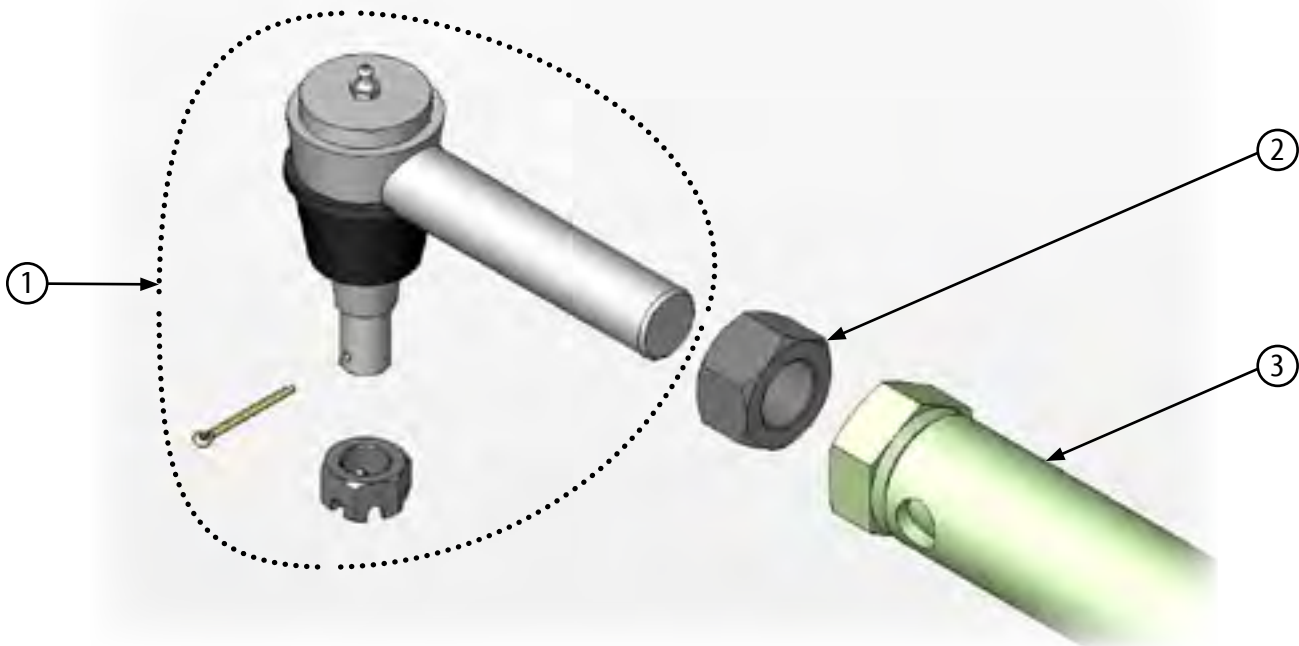

1. 152-624 Ball Joint Male - LH
152-441 Ball Joint Male - RH
2. 102-231 Hex Nut 1 1/8 - 12 LH Threaded
102-086 Hex Nut 1 1/8 - 12 RH Threaded
3. 333-631 Long Tie Rod Tube w/a - 54" total length - 30" row spacing
333-624 Short Tie Rod Tube w/a - 24" total length - 30" row spacing

333-668 Long Tie Rod Tube w/a - 66" total length - 36" row spacing
333-672 Short Tie Rod Tube w/a - 30" total length - 36" row spacing

333-650 Long Tie Rod Tube w/a - 72" total length - 38 - 40" row spacing
333-647 Short Tie Rod Tube w/a - 33" total length - 38 - 40" row spacing



PARTS IDENTIFICATION

ELECTRICAL CABLES AND COMPONENTS

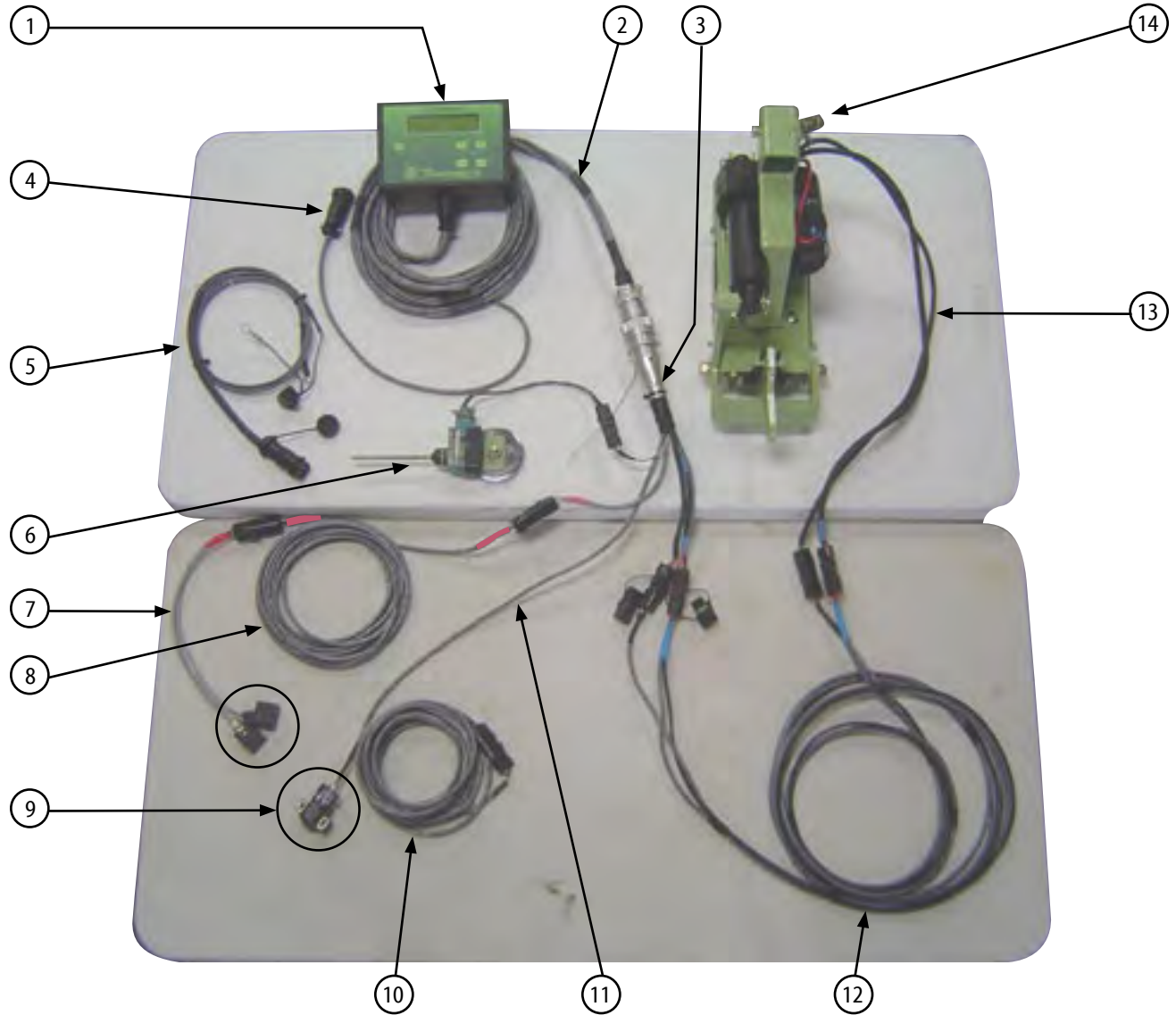

- | | |
|----------------------------|----------------------------|
| 1. 333-899 | 8. 333-682 |
| 2. No part number | 9. 154-649 |
| 3. 305-876 (includes # 11) | 10. 333-683 (refer to # 3) |
| 4. 333-685 | 11. 305-876 |
| 5. 333-014 | 12. 333-684 |
| 6. 305-598 | 13. 305-864 |
| 7. 333-768 | 14. 305-080 |



PARTS IDENTIFICATION

MANIFOLD ASSEMBLY

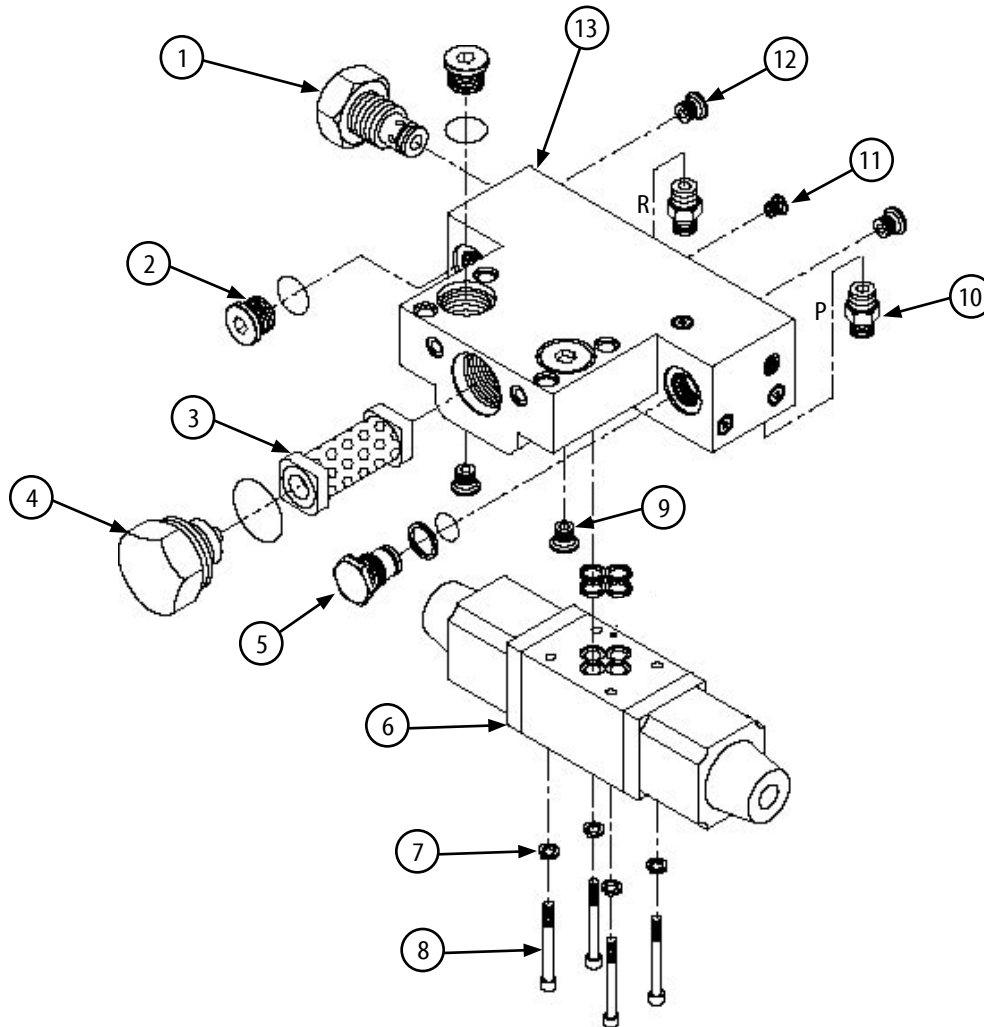

- 1. 180-078 Check Valve
- 2. 198-135 Hollow Plug 9/16 x 18MB (3X)
- 3. 180-130 Filter
- 4. 180-131 Filter Bypass
- 5. 198-286 Cavity Plug
- 6. 180-161 Proportional Valve
- 7. 108-048 Lockwasher (4X)
- 8. 106-111 Screw 10-24 x 1.25" (4X)

- 9. 150-041 Male Plug 7/16 - 20 (2X)
- 10. 198-157 Adaptor 7/16 ORB (2X)
- 11. 198-105 Hollow Plug 5/16 - 24 MB (10X)
- 12. 198-156 Plug 7/16 ORB (2X)
- 13. 180-167 Valve Block

NOTE: 333-678 (not illustrated) Manifold Cable
Entire Assembly: 333-104







